

Programming Manual

PIM Master™

**Passive Intermodulation Analyzer
with Site Master™ Cable &
Antenna Analyzer Option**

MW82119B

Anritsu

TRADEMARK ACKNOWLEDGMENTS

PIM Master, Distance-to-PIM, and Site Master are registered trademarks of Anritsu Company.
Acrobat® and Reader® are registered trademarks of Adobe Corporation
Windows® is a registered trademark of Microsoft Corporation.

NOTICE

Anritsu Company has prepared this manual for use by Anritsu Company personnel and customers as a guide for the proper installation, operation and maintenance of Anritsu Company equipment and computer programs. The drawings, specifications, and information contained herein are the property of Anritsu Company, and any unauthorized use or disclosure of these drawings, specifications, and information is prohibited; they shall not be reproduced, copied, or used in whole or in part as the basis for manufacture or sale of the equipment or software programs without the prior written consent of Anritsu Company.

UPDATES

Updates, if any, can be downloaded from the Anritsu Website at:
<http://www.anritsu.com>

For the latest service and sales contact information in your area, please visit:
<http://www.anritsu.com/contact-us>

Table of Contents

Chapter 1—General Information

1-1	About this Manual	1-1
1-2	Introduction	1-1
1-3	Remote Operation Setup and Interface	1-1
	USB Interface Connection and Setup	1-1
	Ethernet Interface Connection and Setup	1-4
	Connectivity	1-5
	PIM Master LAN Connections	1-5
1-4	Sending SCPI Commands	1-6
	VISA Interactive Control	1-6
	USB Connectivity	1-8
	Ethernet Connectivity	1-10

Chapter 2—Programming with SCPI

2-1	Introduction	2-1
2-2	Introduction to SCPI Programming	2-1
	SCPI Common Commands	2-2
	SCPI Required Commands	2-2
	SCPI Optional Commands	2-2
2-3	Subsystem Commands	2-3
	Command Names	2-3
	Hierarchical Command Structure	2-4
	Query Commands	2-5
	Identifiers	2-6
	Data Parameters	2-6
	Data Parameter Notations	2-7
	Unit Suffixes	2-7
2-4	Notational Conventions	2-8
2-5	Notational Examples	2-9
	Command Terminators	2-9
2-6	Formatting Conventions	2-10
2-7	Parameter Names	2-11

Table of Contents (Continued)

Chapter 3—All Modes Programming Commands

3-1	:FETCh:GPS Subsystem	3-2
	Fetch GPS Fix Data	3-2
3-2	:INSTrument Subsystem	3-3
3-3	:MMEMory Subsystem	3-5
3-4	[:SENSE]:GPS Subsystem	3-8
	GPS On/Off	3-8
	GPS Reset	3-8
	GPS Antenna Current	3-9
	GPS Antenna Voltage	3-9
3-5	:SYSTem Subsystem	3-10

Chapter 4—PIM Analyzer Programming Commands

4-1	SCPI Commands Introduction	4-1
4-2	:CALCulate Subsystem	4-2
4-3	:CALibration Subsystem	4-18
4-4	:DISPlay Subsystem	4-19
4-5	:INITiate Subsystem	4-20
4-6	:MMEMory Subsystem	4-21
4-7	:SENSE Subsystem	4-24
4-8	:TRACe Subsystem	4-38

Chapter 5—Cable & Antenna Commands

5-1	:CALCulate Subsystem	5-1
5-2	:CALibration Subsystem	5-11
5-3	:CONFigure Subsystem	5-12
5-4	:DISPlay Subsystem	5-14
5-5	:FORMat Subsystem	5-16
	Interpreting Returned Data Pair	5-17
5-6	:INITiate Subsystem	5-19
5-7	:MMEMory Subsystem	5-21
5-8	:TRACe Subsystem	5-24
5-9	[:SENSE] Subsystem	5-25

Table of Contents (Continued)

Appendix A—Examples

A-1	C/C++	A-1
A-2	Visual Basic	A-5
A-3	Visual Basic	A-7
A-4	Visual Basic	A-12
A-5	LabVIEW™	A-15

Appendix B—PIM Carrier Bands

B-1	Introduction	B-1
B-2	PIM Master Carrier Bands	B-2

Appendix C—List of Commands by Mode

Appendix D—List of Commands, Alphabetical

Chapter 1 — General Information

1-1 About this Manual

This SCPI Programming Manual provides information for remote operation of the PIM Master MW82119B, Passive Intermodulation (PIM) Analyzer, using commands sent from an external controller through the USB or Ethernet connection.

This Programming Manual includes the following:

- An overview of the USB and Ethernet connections to the instrument.
- An overview of Standard Commands for Programmable Instruments (SCPI) command structure and conventions.
- The IEEE common commands that are supported by the instruments.
- A complete listing and description of all the SCPI commands that can be used to remotely control functions of the instrument. The commands are organized by measurement mode starting in [Chapter 3, “All Modes Programming Commands”](#).

This manual is intended to be used in conjunction with the PIM Master MW82119B User Guide. Refer to the instrument user guide for general information about the instrument, including equipment setup and operating instructions.

1-2 Introduction

This chapter provides a general description of remote programming setup and interface using USB or Ethernet, and sending SCPI commands to the instrument.

1-3 Remote Operation Setup and Interface

Remote operation of the instrument is accomplished via the USB or Ethernet interface. The following paragraphs provide information about the interface connections, cable requirements, and setting up remote operation.

USB Interface Connection and Setup

The Universal Serial Bus (USB) architecture is a high-performance networking standard that is considered “plug and play” compatible. The USB driver software is automatically detected and configured by the operating system of the devices that are connected to the bus. The instrument conforms to the USB 2.0 standard and is a USB “Hi-speed” device that supports data rates of up to 480 Mbps with the following restrictions:

- One USB network can support up to 127 devices
- The maximum length of USB cables between active devices is 5 meters (for USB 2.0) and 3 meters (for USB 1.0)

You must have NI-VISA 2.5 or later installed on the controller PC and must select the VISA library (visa32.dll) as a reference in a Visual Basic project. For remote USB control, the controlling PC needs to have a version of VISA installed that supports USBTMC (USB Test and Measurement Class) devices.

USB Interface, Type Mini-B

The USB 2.0 Mini-B device connector is used to connect the instrument directly to a PC. The first time the instrument is connected to a PC, the normal USB device detection by the computer operating system takes place.

1. Power on the instrument and controller PC and wait for the systems to power up completely.
2. Connect the USB cable Mini-B connector to the instrument.
3. Connect the USB cable A connector to the controller PC USB host port. The controller PC should indicate “New Hardware Found” if the combination of USB VID/PID/Serial Number has never been connected to this controller PC.



Figure 1-1. USB Found New Hardware Wizard

4. Select to allow the Wizard to search for and install the USB software automatically.

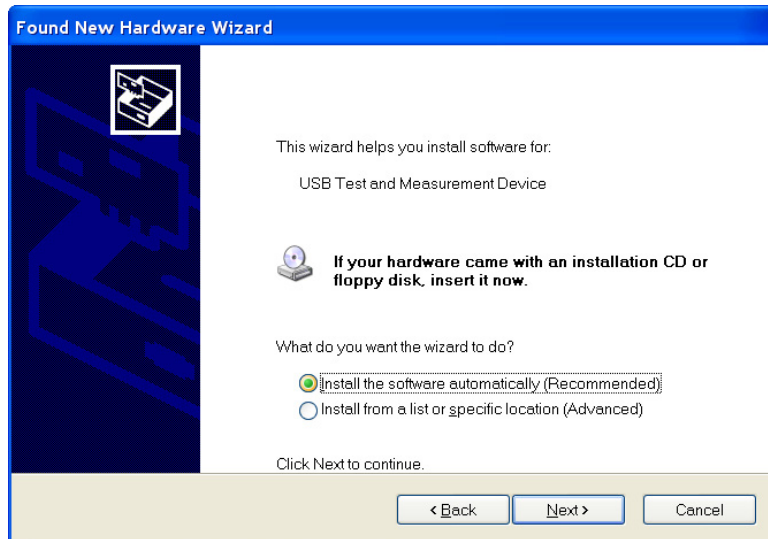

Figure 1-2. USB Found New Hardware Wizard

5. After the software installs, close the Wizard by clicking Finish.



Figure 1-3. USB Found New Hardware Wizard

Ethernet Interface Connection and Setup

The PIM Master MW82119B fully supports the IEEE-802.3 standard. Most PIM Master functions (except power On/Off) can be controlled via an Ethernet connection to a PC that is connected directly (with an Ethernet cross-over cable) or through a network.

Ethernet networking uses a bus or star topology in which all of the interfacing devices are connected to a central cable called the bus, or are connected to a hub. Ethernet uses the CSMA/CD access method to handle simultaneous transmissions over the bus. CSMA/CD stands for Carrier Sense Multiple Access/Collision Detection. This standard enables network devices to detect simultaneous data channel usage (called a collision) and provides for a contention protocol. When a network device detects a collision, the CSMA/CD standard dictates that the data is retransmitted after waiting a random amount of time. If a second collision is detected, then the data are again retransmitted after waiting twice as long. This is known as exponential back off.

The TCP/IP setup requires the following:

- **IP Address:** Every computer/electronic device in a TCP/IP network requires an IP address. An IP address has four numbers (each between 0 and 255) separated by periods. For example: 128.111.122.42 is a valid IP address.
- **Subnet Mask:** The subnet mask distinguishes the portion of the IP address that is the network ID from the portion that is the station ID. The subnet mask 255.255.0.0, when applied to the IP address given above, would identify the network ID as 128.111 and the station ID as 122.42. All stations in the same local area network should have the same network ID, but different station IDs.
- **Default Gateway:** A TCP/IP network can have a gateway to communicate beyond the LAN that is identified by the network ID. A gateway is a computer or electronic device that is connected to two different networks and can move TCP/IP data from one network to the other. A single LAN that is not connected to other LANs requires a default gateway setting of 0.0.0.0. If you have a gateway, then the default gateway would be set to the appropriate value of your gateway.
- **Ethernet Address:** An Ethernet address (also known as a MAC address) is a unique 48-bit value that identifies a network interface card to the rest of the network. Every network card has a unique ethernet address permanently stored into its memory.

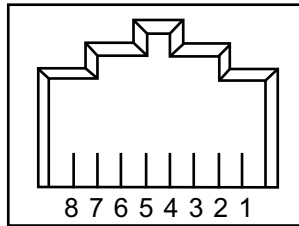
Table 1-1. 8-pin Ethernet RJ45 Connector Pinout Diagram

Pin	Name	Description	Wire Color
1	TX+	Transmit data (> +3 volts)	White/Orange
2	TX-	Transmit data (< -3 volts)	Orange
3	RX+	Receive data (> +3 volts)	White/Green
4	—	Not used (common mode termination)	Blue
5	—	Not used (common mode termination)	White/Blue
6	RX-	Receive data (< -3 volts)	Green
7	—	Not used (common mode termination)	White/Brown
8	—	Not used (common mode termination)	Brown

Connectivity

TCP/IP connectivity requires setting up the parameters that are described at the beginning of this section. The following is a brief overview of how to set up a general LAN connection on the PIM Master.

Note

You may need to consult your network documentation or network administrator for assistance in configuring your network setup.

PIM Master LAN Connections

The RJ-45 connector is used to connect the PIM Master to a local area network (LAN). Integrated into this connector are two LEDs. The amber LED (Light Emitting Diode) indicates the speed of the LAN connection (ON for 100 Mb/s and OFF for 10 Mb/s), and the green LED flashes to show that LAN traffic is present. The instrument IP address is set automatically by using Dynamic Host Configuration Protocol (DHCP). DHCP is an Internet protocol that automates the process of setting IP addresses for devices that use TCP/IP, and is the most common method of configuring a device for network use. After the Ethernet cable is connected to the instrument, go to System, then Status (key sequence: **Shift** > **System** (9) > **Status**) to view the IP address that the instrument has been assigned.

1-4 Sending SCPI Commands

SCPI commands can be sent to the instrument through any Virtual Instrument Software Architecture (VISA) controller. VISA is a commonly used API in the Test and Measurement industry for communicating with instruments from a PC. The physical connection between the PC and the instrument is USB or Ethernet. NI-VISA is the National Instruments implementation of the VISA I/O standard. Information and downloads are available at: <http://www.ni.com/visa/>

The following examples describe the verification that a VISA controller can interact with the instrument. The images shown and the instructions for your instrument and software may differ from the examples.

Note Before remote operation, confirm that the instrument is not in the Menu screen. Sending commands while the Menu screen is displayed is an invalid operation. See your User Guide regarding the Menu screen.

VISA Interactive Control

1. On the PC, run VISA Interactive Control and double-click on the instrument.

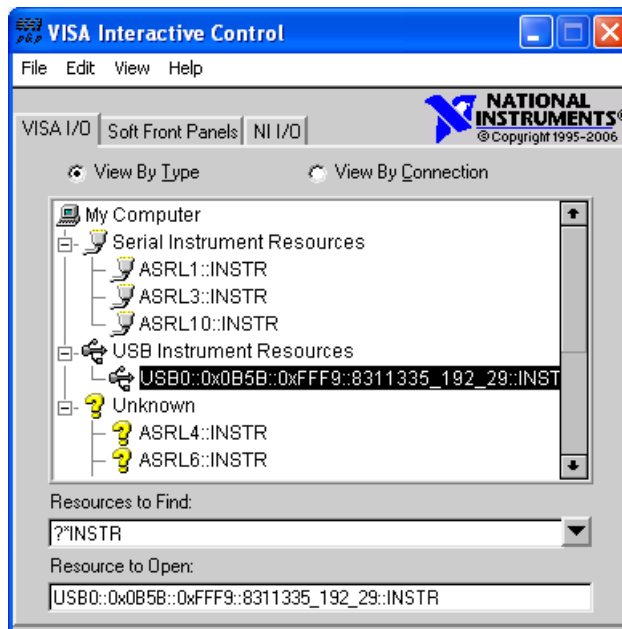

Figure 1-4. VISA Interactive Control

2. Select the viWrite tab and execute the default *IDN? write by clicking the Execute button.

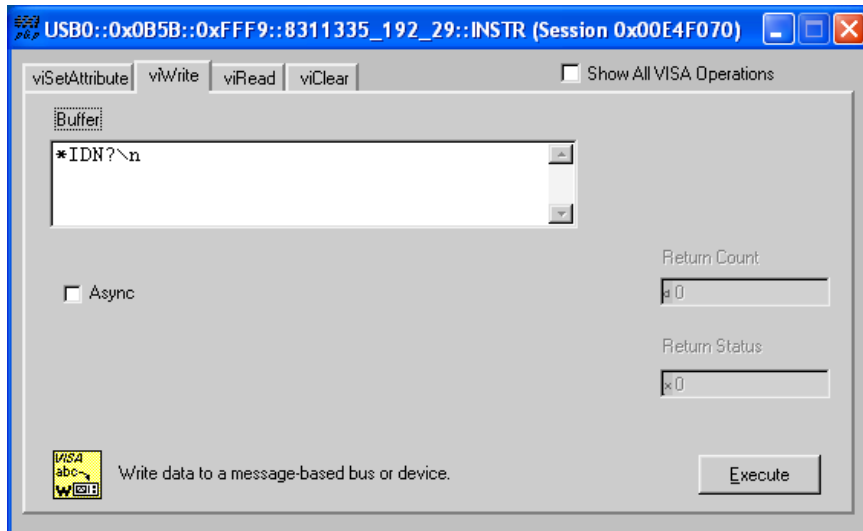

Figure 1-5. VISA Interactive Control viWrite Tab

3. Select the viRead tab and click the Execute button. If the PC is connected to the instrument the command returns the following information from the Buffer: manufacturer name ("Anritsu"), model number/options, serial number, and firmware package number.

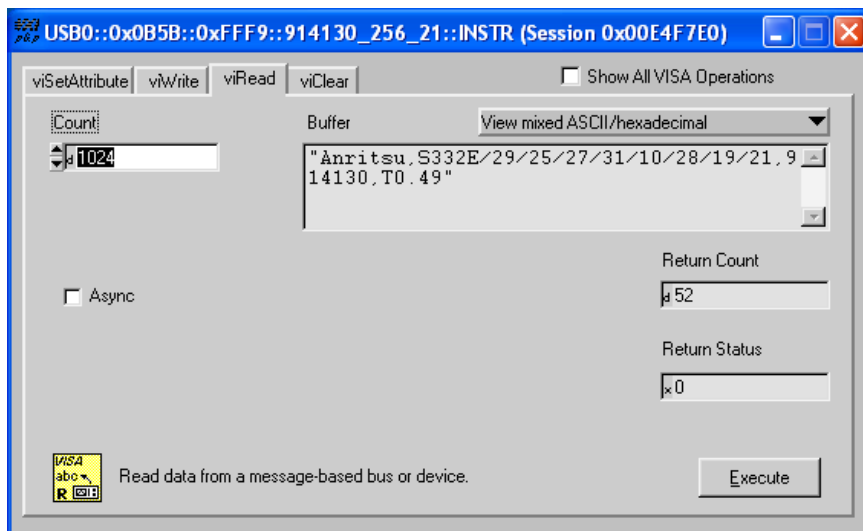

Figure 1-6. VISA Interactive Control viRead Tab

USB Connectivity

1. On the PC, run NI Measurement & Automation Explorer or VISA Interactive Control and double-click on the TMC Class instrument.

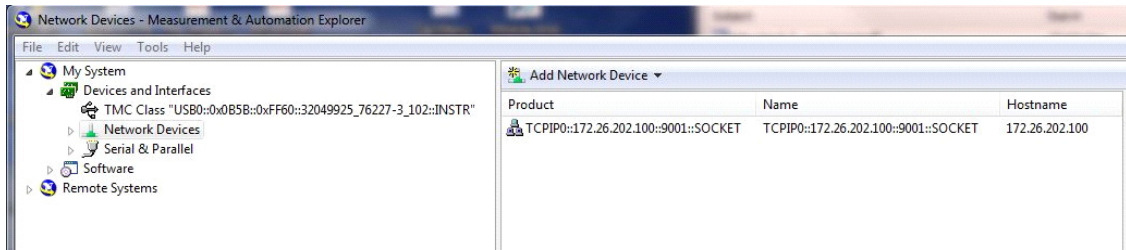

Figure 1-7. Figure 1-4. NI Measurement & Automation Explorer

2. Verify that the USB Settings list the correct Manufacturer, Model, and Serial Number, as shown in the example below.

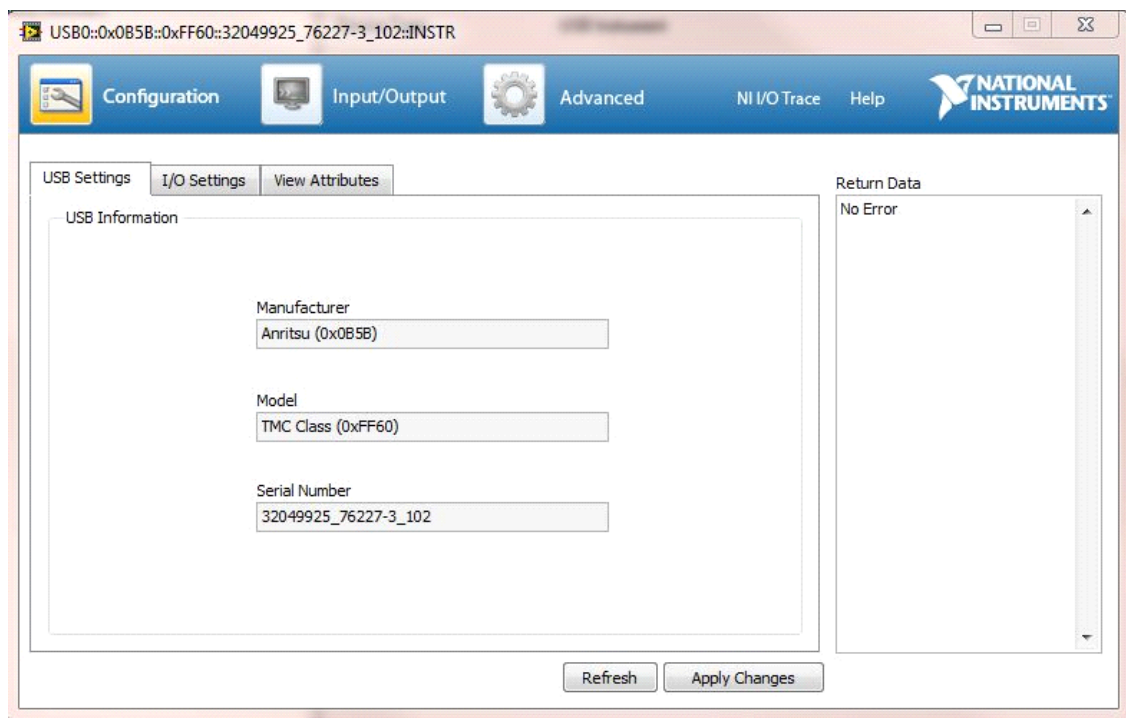

Figure 1-8. NI VISA Interactive Control USB Configurations / Settings Tab.

3. Select the Input/Output, Basic I/O tab and execute the default *IDN? Query. If the PC is connected to the instrument, then the command returns the following information from

the Buffer: manufacturer name (“Anritsu”), model number/options, serial number, and firmware package number, as shown in the example below.

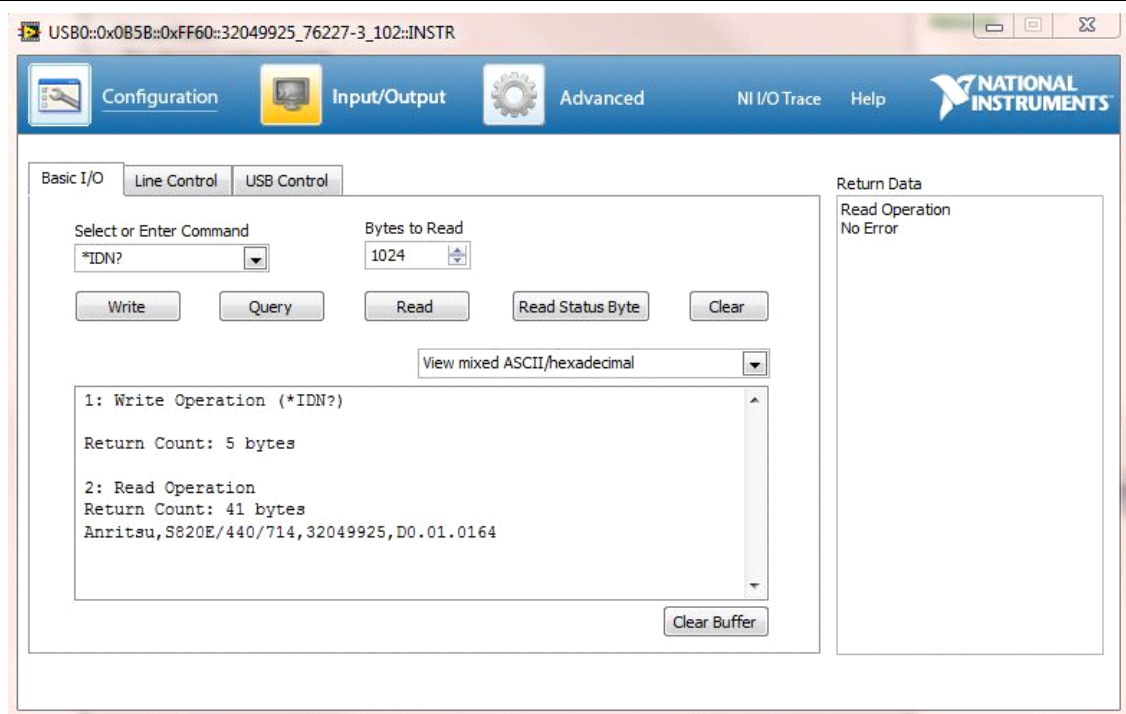

Figure 1-9. NI VISA Interactive Control USB Basic I/O Tab.

Ethernet Connectivity

1. On the PC, run NI Measurement & Automation Explorer or VISA Interactive Control and create a new LAN Resource under Network Devices. Add the TCP/IP resource using a Manual Entry of Raw Socket, as shown in the example below.

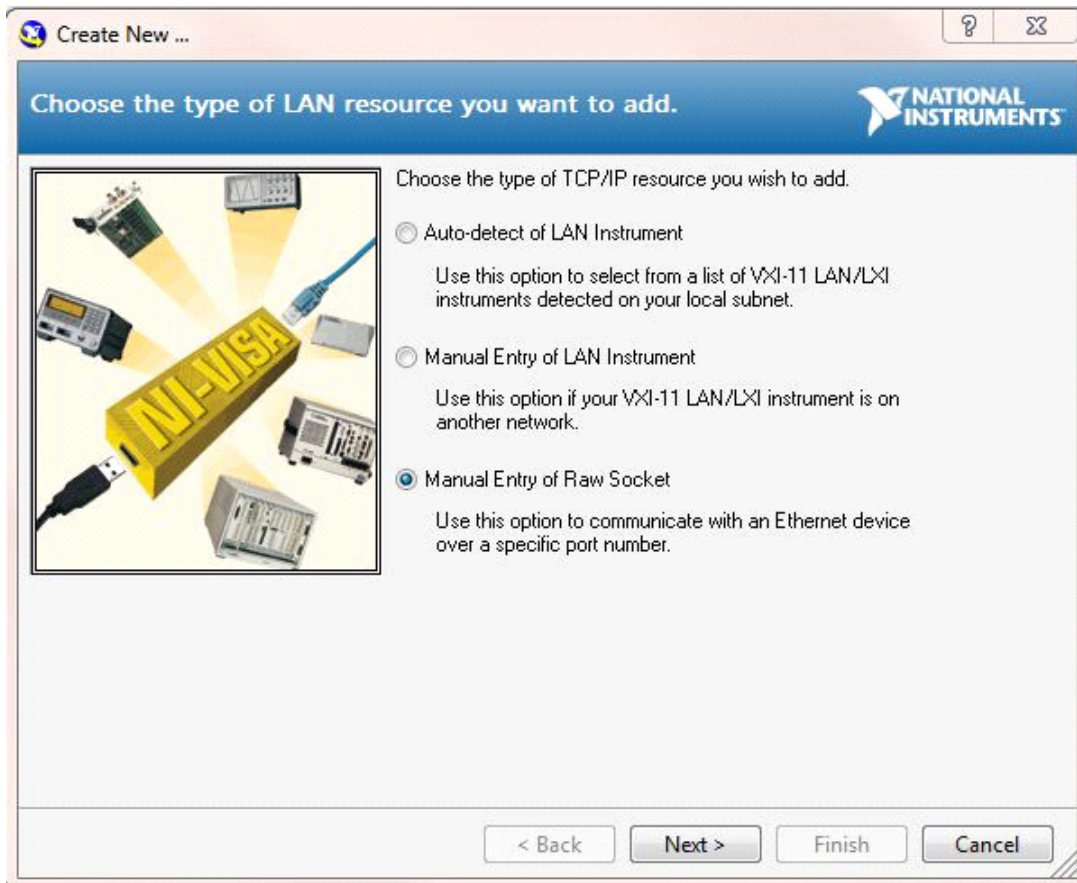

Figure 1-10. NI VISA Interactive Control LAN resource addition using Raw Socket.

- Enter the IP address that the instrument has acquired (go to **System (9)**, Status). Enter the port number as 9001, as shown in the example below.

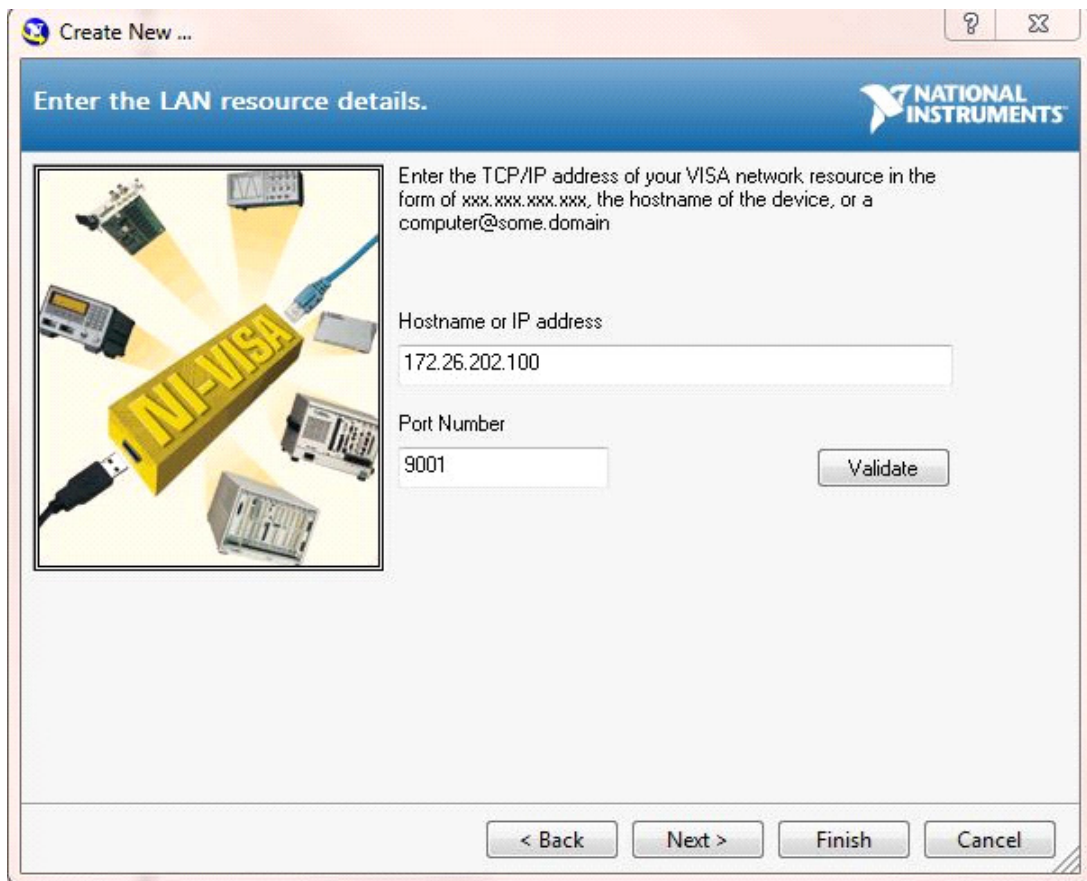

Figure 1-11. NI VISA Interactive Control LAN resource settings of IP address and port number.

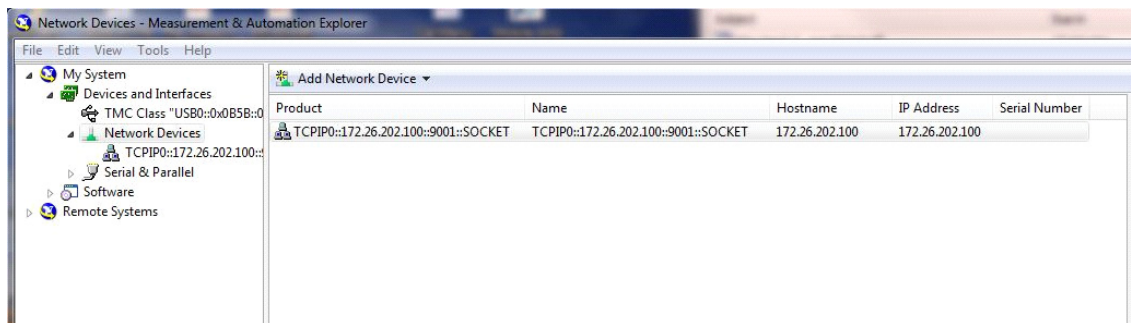

Figure 1-12. NI VISA Interactive Control LAN resource validated.

3. Select the Configuration I/O settings tab and verify that the Termination Methods are set as shown in the example below.

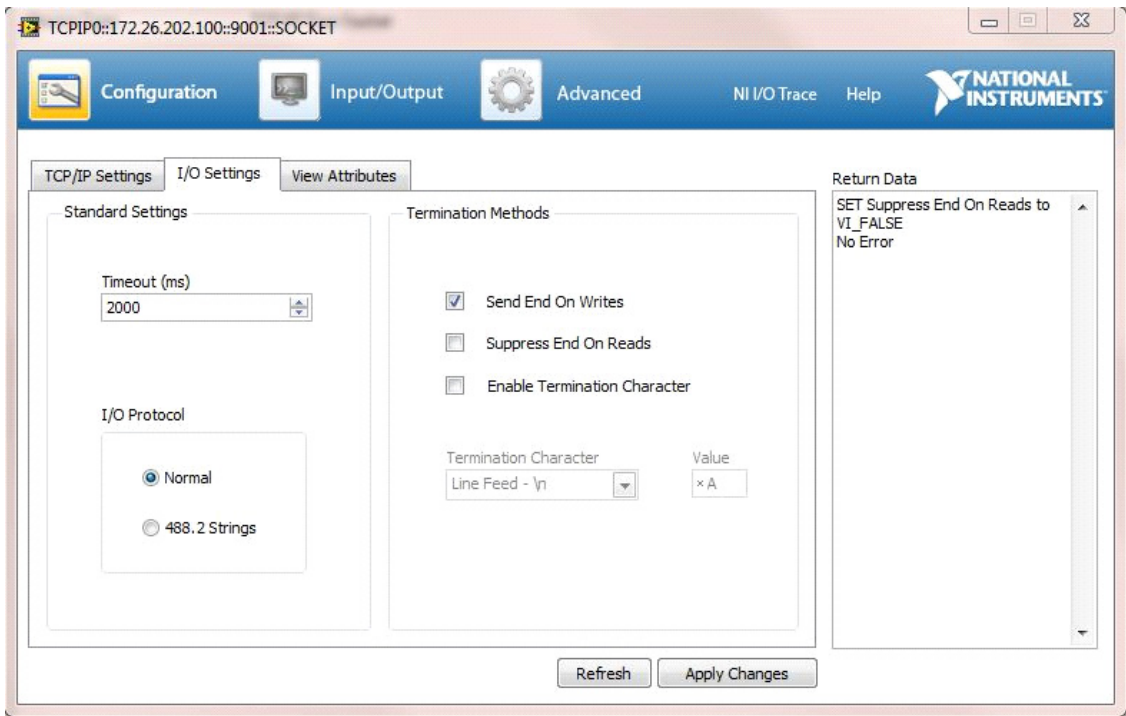

Figure 1-13. NI VISA Interactive Control LAN resource I/O Termination Method Settings

4. Select the Input/Output Basic I/O tab and execute the default *IDN? Query. If the PC is connected to the instrument, then the command returns the following information from

the Buffer: manufacturer name (“Anritsu”), model number/options, serial number, and firmware package number, as shown in the example below.

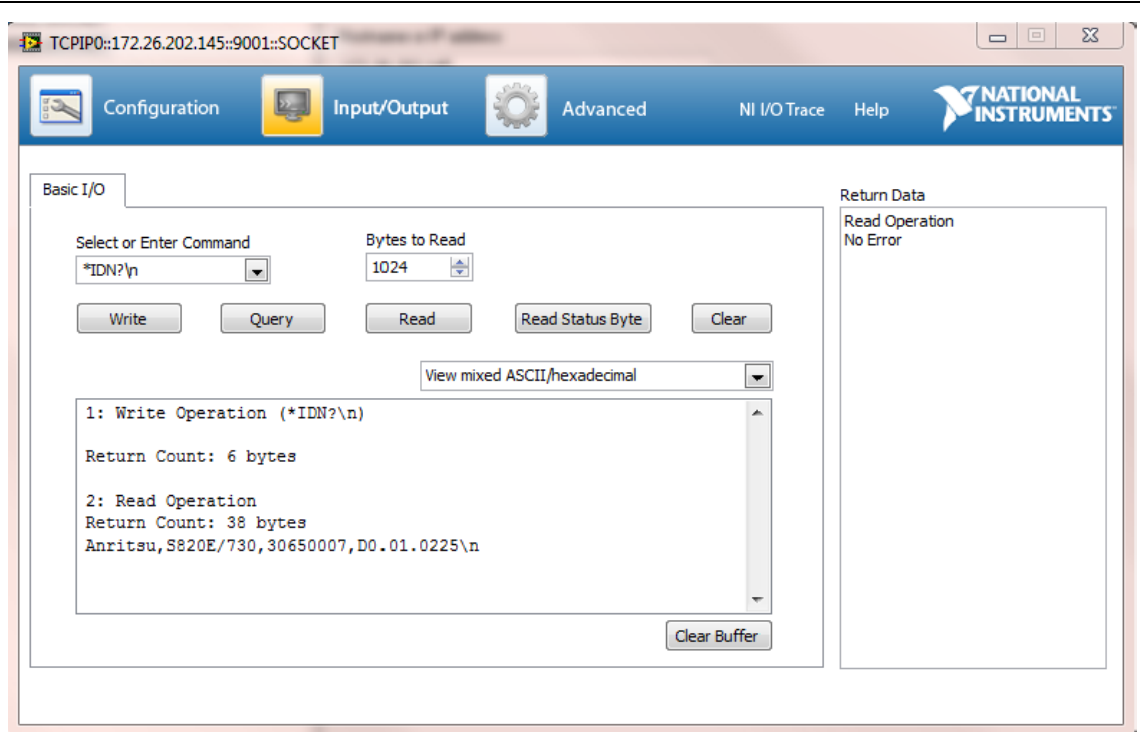

Figure 1-14. NI VISA Interactive Control USB Basic I/O Tab.

When sending SCPI commands over Ethernet, you are required to send a newline termination character at the end of each command. In the example above, a newline character (“\n” in this case, but could be different depending on your programming environment) was used to terminate the *IDN? command.

Note

When sending query commands over raw socket, the entire buffer must be read before the next query command is sent. Each query result is terminated by a newline to help identify the end of the query response. Query read operations could be broken into multiple reads, if necessary.

When using raw socket connections, you must close a session before opening a new one or before switching to a new protocol (such as USB). If you try to open a new session or switch protocols without first closing the previously opened session, then you may lose communications with the instrument and may not be able to reconnect until you reboot the instrument.

Chapter 2 — Programming with SCPI

2-1 Introduction

This chapter provides an introduction to Standard Commands for Programming Instruments (SCPI) programming that includes descriptions of the command types, hierarchical command structure, command subsystems, data parameters, and notational conventions.

2-2 Introduction to SCPI Programming

Anritsu instruments can be operated with the use of SCPI commands. SCPI is intended to give the user a consistent environment for program development. It does so by defining controller messages, instrument responses, and message formats for all SCPI compatible instruments. SCPI commands are messages to the instrument to perform specific tasks. The command set includes:

- [“SCPI Common Commands” on page 2-2](#)
- [“SCPI Required Commands” on page 2-2](#)
- [“SCPI Optional Commands” on page 2-2](#)

Note

The PIM Master follows the SCPI standard, but is not fully compliant with that standard. The main reason that the PIM Master is not fully compliant is because it does not support all of the required SCPI commands, and because it uses some exceptions in the use of short form and long form command syntax.

SCPI Common Commands

Some common commands are defined in the IEEE-488.2 standard and must be implemented by all SCPI compatible instruments. These commands are identified by the asterisk (*) at the beginning of the command keyword. These commands are defined to control instrument status registers, status reporting, synchronization, and other common functions. For example, *IDN? is a common command supported by the PIM Master.

SCPI Required Commands

The required SCPI commands supported by the instrument are listed in the [Table 2-1](#).

Table 2-1. SCPI Required Commands

:STATus
:SYSTem

SCPI Optional Commands

[Table 2-2](#) lists the optional SCPI commands that comprise the majority of the command set described in this document. These commands control most of the programmable functions of the instrument.

Table 2-2. SCPI Optional Commands

:ABORt	:FETCh	:MEASure	:TRACe
:CALCulate	:FORMat	:MMEMory	:TRIGger
:CALibration	:INITiate	:READ	:UNIT
:CONFigure	:INPut	:SENSe	: [SENSe]
:DISPlay	:INSTrument	:SOURce	

The SCPI optional commands are sorted by measurement modes, and commands may be repeated in more than one mode.

- [Chapter 3, “All Modes Programming Commands”](#)
- [Chapter 4, “PIM Analyzer Programming Commands”](#)
- [Chapter 5, “Cable & Antenna Commands”](#)

2-3 Subsystem Commands

Subsystem commands control all instrument functions and some general purpose functions. All subsystem commands are identified by the colon used between keywords, as in `:INITiate:CONTinuous`.

The following information is provided for each subsystem command described in the following chapters.

- The command name, refer to [“Command Names” on page 2-3](#).
- The path from the subsystem root command, refer to [“Hierarchical Command Structure” on page 2-4](#).
- The query form of the command (if applicable), refer to [“Query Commands” on page 2-5](#).
- A description of the purpose of the command.
- The data parameters that are used as arguments for the command, refer to [“Data Parameters” on page 2-6](#). This may include the parameter type and the available parameter choices.

Command Names

Typical SCPI commands consist of one or more keywords, parameters, and punctuation. SCPI command keywords can be a mixture of upper and lower case characters. Except for common commands, each keyword has a long and a short form. In this manual, the long form is presented with the short form in upper case and the remainder in lower case. For example, the long form of the command keyword to control the instrument display is `:DISPlay`.

The short form keyword is usually the first four characters of the long form (example: `DISP` for `DISPlay`). The exception to this is when the long form is longer than four characters and the fourth character is a vowel. In such cases, the vowel is dropped and the short form becomes the first three characters of the long form. Example: the short form of the keyword `:POWer` is `:POW`.

Some command keywords may have a numeric suffix to differentiate between multiple instrument features such as multiple trace options. For example, `:CALCulate#:DATA? FDATA | SDATA | FMEM | SMEM` can result in two different commands, one for trace 1 "`:CALC1:DATA? FDATA`" and another for trace 2 "`:CALC2:DATA? FMEM`".

Note	If a numeric suffix is not included in a command, the first option is implied. Curly brackets { } designate optional keyword or command parameters. Square brackets [] designate optional command keywords. For example, the command <code>:TRACe[:DATA]? {1 2}</code> can be sent as <code>:TRACe?</code> or <code>:TRACe? 1</code> , or as <code>:TRAC?</code> or <code>:TRAC? 1</code> to obtain data from trace 1.
-------------	---

As with any programming language, the exact command keywords and command syntax must be used. The syntax of the individual commands is described in detail in the programming command chapters. Unrecognized versions of long form or short form commands, or improper syntax, will generate an error.

Long Format vs. Short Format

Each keyword has a long format and a short format. The start frequency can be specified by `:SENSE:FREQUENCY:START` or `:SENS:FREQ:STAR`. The capital letters in the command specification indicate the short form of the command. A mixture of the entire short form elements with entire long form elements of each command is acceptable. For example, `:SENS:FREQUENCY:STAR` is an acceptable form of the command. However, `:SENS:FREQUen:STA` is not an acceptable form of the command because `:FREQUen` is not the entire short or long form of the command element.

Hierarchical Command Structure

All SCPI commands, except the common commands, are organized in a hierarchical structure similar to the inverted tree file structure used in most computers. The SCPI standard refers to this structure as “the Command Tree.” The command keywords that correspond to the major instrument control functions are located at the top of the command tree. The root command keywords for the SCPI command set are shown in [Figure 2-1](#).

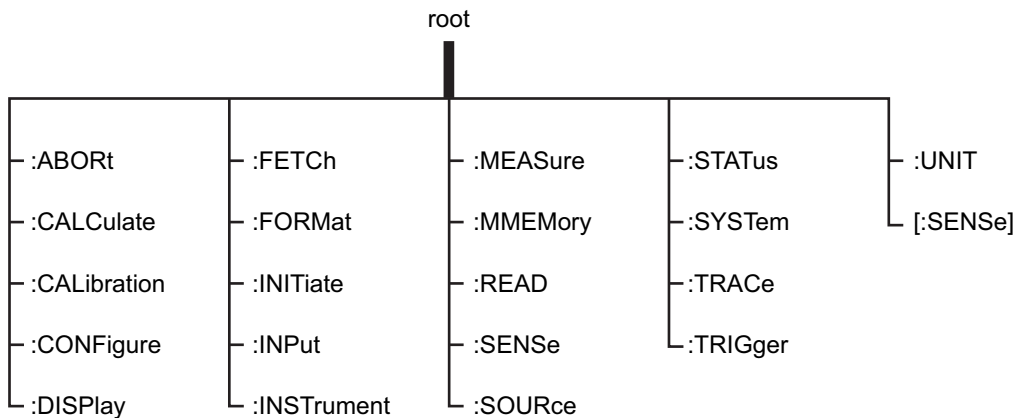

Figure 2-1. SCPI Command Tree

All instrument SCPI commands, except the `:ABORT` command, have one or more subcommands (keywords) associated with them to further define the instrument function to be controlled. The subcommand keywords may also have one or more associated subcommands (keywords). Each subcommand level adds another layer to the command tree. The command keyword and its associated subcommand keywords form a portion of the command tree called a command subsystem. The `:CONFIGure` command subsystem is shown in [Figure 2-2](#).

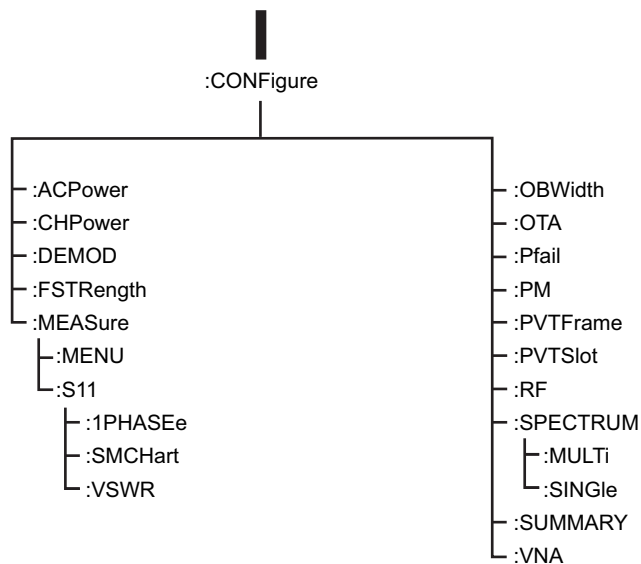

Figure 2-2. SCPI :CONFigure Subsystem

A colon (:) separates each subsystem. For example, the command `:SENSE:FREQUENCY:START <freq>` sets the start frequency. The start frequency is part of the `:FREQUENCY` subsystem which is part of the `:SENSE` subsystem. Stop frequency is also part of the `:SENSE:FREQUENCY` subsystem. It is specified by `:SENSE:FREQUENCY:STOP`.

Query Commands

All commands, unless specifically noted in the commands syntax descriptions, have a query form. As defined in IEEE-488.2, a query is a command with a question mark symbol appended (examples: `*IDN?` and `:OPTions?`). When a query form of a command is received, the current setting associated with the command is placed in the output buffer. Query commands always return the short form of the parameter unless otherwise specified. Boolean values are returned as 1 or 0, even when they can be set as on or off.

Identifiers

The following identifiers have been used throughout the optional command definitions. Descriptions are provided here. In most cases, units are specified with the individual command.

Table 2-3. Description of Command Identifiers

Identifier	Description
<amplitude>	Amplitude value. Units specified with the command.
<freq>	Frequency. Units specified with the command.
<integer>	Integer value, no units. Range specified with the command.
<number>	Numeric value, integer, or real.
<percentage>	Percentage value from 0 to 00. Units are always %.
<rel ampl>	Relative amplitude. Units are always dB.
<x-parameter>	Parameter value in the units of the x-axis. Units are specified with the command.
<string>	The string should be enclosed in either single quotes (' ') or double quotes (" ").
<file name>	The name should be enclosed in either single quotes (' ') or double quotes (" "). The need for an extension is documented with applicable commands.
<voltage>	Voltage. Units specified with the command.
<current>	Current. Units specified with the command.

Data Parameters

Data parameters, referred to simply as “parameters”, are the quantitative values that are used as arguments for the command keywords. The parameter type that is associated with a particular SCPI command is determined by the type of information required to control the particular instrument function. For example, Boolean (ON | OFF) type parameters are used with commands that control switch functions.

Some command descriptions specify the type of data parameter to be used with each command. The most commonly used parameter types are numeric, extended numeric, discrete, and Boolean.

Numeric: Numeric parameters comprise integer numbers or any number in decimal or scientific notation, and may include polarity signs.

Discrete: Discrete parameters, such as INTernal and EXTernal, are used to control program settings to a predetermined finite value or condition.

Boolean: Boolean parameters represent binary conditions and may be expressed as ON, OFF or 1, 0. Boolean parameters are always returned by query commands as 1 or 0 in numeric value format.

Data Parameter Notations

The following syntax conventions are used for data parameter descriptions in this manual:

Table 2-4. Parameter Notations

<arg>	::=a generic command argument consisting of one or more of the other data types
<bNR1>	::=boolean values in <NR1> format; numeric 1 or 0
<boolean>	::=ON OFF. Can also be represented as 1 or 0, where 1 means ON and 0 means OFF Boolean parameters are always returned as 1 or 0 in <NR1> format by query commands
<integer>	::=an unsigned integer without a decimal point (implied radix point)
<NR1>	::=a signed integer without a decimal point (implied radix point)
<NR2>	::=a signed number with an explicit radix point
<NR3>	::=a scaled explicit decimal point numeric value with and exponent (e.g., floating point number)
<NRf>	::=<NR1> <NR2> <NR3>
<nv>	::=SCPI numeric value: <NRf> MINimum MAXimum UP DOWN DEFault NAN (Not A Number) INFinity NINFinity (Negative Infinity) or other types
<char>	::=<CHARACTER PROGRAM DATA> Examples: CW, FIXed, UP, and DOWN
<string>	::=<STRING PROGRAM DATA> ASCII characters enclosed by double quotes For example: "OFF"
<block>	::=IEEE-488.2 block data format
<NA>	::=Not Applicable

Unit Suffixes

Unit suffixes are not required for data parameters, provided the values are scaled for the global default units. The instrument SCPI default units are: Hz (Hertz) for frequency-related parameters, s (seconds) for time-related parameters, and m (meters) for distance-related parameters.

2-4 Notational Conventions

The SCPI interface standardizes command syntax and style that simplifies the task of programming across a wide range of instrumentation. As with any programming language, the exact command keywords and command syntax must be used. Unrecognized commands or improper syntax will not function.

Table 2-5. Notational Conventions

:	A colon links command keywords together to form commands. The colon is not an actual part of the keyword, but is a signal to the SCPI interface parser. A colon must precede a root keyword immediately following a semicolon (see “Notational Examples” on page 2-9).
;	A semicolon separates commands if multiple commands are placed on a single program line.
[]	Square brackets enclose one or more optional keywords.
{ }	Braces enclose one or more keyword or command parameters that may be included zero or more times.
	A vertical bar indicates “or” and is used to separate alternative parameter options. Example: ON OFF is the same as ON or OFF.
< >	Angle brackets enclose parameter descriptions.
::=	Means “is defined as” For example: <a>::=<c> indicates that <c> can replace <a>.
sp	Space, referred to as <i>white space</i> , must be used to separate keywords from their associated data parameters. It must not be used between keywords or inside keywords.
xxx	Indicates a root command name
#	Indicates an integer value selection from a range of values

For further information about SCPI command syntax and style, refer to the Standard Commands for Programmable Instruments (SCPI) 1999.0 document.

2-5 Notational Examples

Table 2-6 provides examples of valid command syntax:

Table 2-6. Creating Valid Commands

Command Specification	Valid Forms
<pre>[:SENSE] :FREQuency :STARt <frequency> { Hz kHz MHz GHz }</pre>	<p>The following all produce the same result:</p> <pre>:SENSe:FREQuency:STARt 1 MHZ :SENS:FREQ:STAR 1 MHZ :sense:frequency:start 1000000 :FREQ:STAR 1000 KHZ</pre>
<pre>:CALCulate:MARKer#:X <value> { Hz kHz MHz GHz, m cm mm, ft }</pre>	<p>The first 2 commands set the location of marker 1. The third command sets the location of marker 2.</p> <pre>:CALC:MARK:X 1 GHZ :CALC:MARK1:X 1 GHZ :CALC:MARK2:X 2 GHZ</pre>
<pre>:INITiate:CONTInuous OFF ON 0 1</pre>	<p>The following commands are identical:</p> <pre>:INITiate:CONTInuous OFF :init:cont 0</pre>

Command statements read from left to right and from top to bottom. In the command statement above, the `:FREQuency` keyword immediately follows the `:SENSe` keyword with no separating space. A space (*sp*) is used between the command string and its argument.

Note that the first keyword in the command string does not require a leading colon; however, it is good practice to always use a leading colon for all keywords. Note also that the `:SENSe` keyword is optional. This is a SCPI convention for all voltage or signal source type instruments that allows shorter command statements to be used.

The following is an example of a multiple command statement that uses two separate commands in a single statement:

```
:FREQuency:STARt 10E6 ; :FREQuency:STOP 20E9
```

Note

A semicolon is used to join the commands and a leading colon used immediately after the semicolon to start the second command.

Command Terminators

The `<new line>` character (ASCII 10) in the last data byte of a command string is used as a command terminator. Use of a command terminator resets the command path to the root of the tree.

2-6 Formatting Conventions

This manual uses the conventions listed below in describing SCPI commands. The abbreviations “Cmd” and “Param” are used to represent “Command” and “Parameter”.

Table 2-7. Formatting Conventions

:COMMands:LOOK:LIKE:THIS	Commands are formatted to differentiate them from their description.
:COMMand:QUERies:LOOK:LIKE:THIS?	The query form of the command is followed by a “?”
<identifier>	Identifiers are enclosed in “< >”. They indicate that some type of data must be provided.
	The “ ” indicates that a choice must be made.
[optional input]	Optional input is enclosed in “[]”. The “[]” are not part of the command.

2-7 Parameter Names

The following tables list the parameter options for the `:TRACe:PREamble?` command in each supported measurement mode.

Cable & Antenna Parameter Names

Table 2-8. Available Parameters in Cable & Antenna Mode (1 of 4)

Parameter Name	Description
SN	Instrument serial #
UNIT_NAME	Instrument name
TYPE	The data type (Setup or Data).
DESCR	Trace name
DATE	Trace date/time
BASE_VER	Base FW version
APP_NAME	Application name
APP_VER	Application FW version
APP_MODE	Application Mode
CHECKSUM	Checksum
DIST_UNITS	Distance units
AMPL_UNITS	y-axis value units
MEASUREMENT	Measurement
1PORT_DOMAIN	1-Port Domain
FREQ_START	Start Frequency
FREQ_STOP	Stop Frequency
DIST_START	Start distance
DIST_STOP	Stop distance
CAL_STATUS	Calibrate Status (On/Off)
SWEEP_TIME	Sweep time
SWEEP_TYPE	Sweep type (Single/Continuous)
MARKER_SELECTED	The selected marker
MARKER_TABLE	Marker table status (On/Off)
TRACE_VIEW	Trace View (View/Blank)
TRACE_STATE	Trace State (Write/Hold)
WINDOWING	Windowing Type (Rectangular/Nominal Side Lobe/ Low Side Lobe/Minimum Side Lobe)
CABLE	Cable index from the cable list
PROP_VEL	Propagation velocity
CABLE_LOSS	Cable Loss
CW_STATUS	RF Immunity (On/Off)

Table 2-8. Available Parameters in Cable & Antenna Mode (2 of 4)

Parameter Name	Description
OUTPUT_POWER_LEVEL	Power Level (High/Low)
CURRENT_SIGNAL_STD	Current signal standard
RESOLUTION	Sweep Resolution (137/275/551)
SCALE	Y-axis scale
RF_SOURCE_POWER_LEVEL	Source Power Level
CAL_TEMP_WINDOW	Cal Temp window
CAL_COEFFICIENT_PTR	Calibrate coefficient
SMITH_CHART_TYPE	Smith chart type
DISPLAY_CHANNELS	Display Channels
ACTIVE_DISPLAY_CHANNEL	The current active display channel
NUM_OF_CHANNELS	Channel number
SEND_CAL_PROMPTS	Send Cal prompts
SET_SWEEP_DATA_TYPE	Set sweep data type
AVERAGING	Averaging
DISP_CHANNELS	Display channels
ACTIVE_DISP_CHANNEL	Active display channel
DMAX	Dmax
FAULT_RESOLUTION	Fault Resolution
SUGGESTED_SPAN	Suggested span
START_FREQ_STATUS	Start frequency status
AVERAGING_FACTOR	Averaging Factor.
AVERAGE_COUNT	Averaging count.
SCALE_RESOLUTION_RL_DIST	S_{11} Log Magnitude Fault Location scale resolution
SCALE_RESOLUTION_SWR	S_{11} VSWR scale resolution
SCALE_RESOLUTION_SWR_DIST	S_{11} VSWR Fault Location scale resolution
SCALE_RESOLUTION_CL	Cable loss Scale resolution
SCALE_RESOLUTION_IL	IL scale resolution
SCALE_RESOLUTION_IG	S_{21} Log Magnitude scale resolution
SCALE_RESOLUTION_PHASE_S11	S_{11} Phase scale resolution
REFERENCE_VALUE_PHASE_S11	S_{11} Phase reference value
REFERENCE_LINE_PHASE_S11	S_{11} Phase reference line
RL_DIST_BOTTOM	DTF Return Loss Bottom Value
SWR_DIST_TOP	DTF VSWR Top Value
SWR_DIST_BOTTOM	DTF VSWR Bottom Value
RL_MAG_TOP	Return Loss Top Value

Table 2-8. Available Parameters in Cable & Antenna Mode (3 of 4)

Parameter Name	Description
RL_MAG_BOTTOM	Return Loss Bottom Value
SWR_MAG_TOP	VSWR Top Value
SWR_MAG_BOTTOM	VSWR Bottom Value
CL_MAG_TOP	Cable Loss Top Value
CL_MAG_BOTTOM	Cable Loss Bottom Value
S11_PHASE_TOP	1-Port Phase Top Value
S11_PHASE_BOTTOM	1-Port Phase Bottom Value
MKR_REF_FREQNx	Reference marker x frequency (where x is the marker number 0–5)
MKR_REF_FLAGSx	Reference marker x flags: MKR_FLAG_ON_OFF: 0x00000001 MKR_FLAG_DELTA_MKR: 0x00000020 MKR_FLAG_DATA_INVALID: 0x00000040 MKR_FLAG_DATA_STALE: 0x00000080 MKR_FLAG_SELECTED: 0x00000100 MKR_FLAG_DELT_DISPL_PER_HZ: 0x00000800 MKR_FLAG_TRACE_A: 0x00001000 MKR_FLAG_TRACE_B: 0x00002000 MKR_FLAG_TRACE_MASK: 0x00007000
MKR_DLT_FREQNx	Delta marker x frequency (where x is the marker number 0–5)
MKR_DLT_FLAGSx	Delta marker x flags:
LIM_LFLAGS_UP-1	Upper limit flags: LIMIT_FLAG_UPPER: 0x00000001 LIMIT_FLAG_ON: 0x00000004 LIMIT_FLAG_ALARM_ON: 0x00000002 LIMIT_FLAG_SEGMENTED: 0x00000020 LIMIT_FLAG_ALARM_EVENT: 0x00000040 LIMIT_FLAG_LEFT_OF_START_FREQ: 0x00000080 LIMIT_FLAG_RIGHT_OF_STOP_FREQ: 0x00000100 LIMIT_FLAG_MASK: 0x000007FF
LIM_NUMPTS_UP-1	Number of upper limit points
LIM_CURFRQ_UP-1	Upper limit current frequency
LIM_CURMAG_UP-1	Upper limit current magnitude

Table 2-8. Available Parameters in Cable & Antenna Mode (4 of 4)

Parameter Name	Description
LIM_PFLAGS_UPx	Upper limit x flags (where x is the limit point number starting with 0)
LIM_FREQNC_UPx	Upper limit point x freq (where x is the limit point number starting with 0)
LIM_MAGNTD_UPx	Upper limit point x parameter (where x is the limit point number starting with 0)

Chapter 3 — All Modes Programming Commands

The Anritsu PIM Master is capable of producing 80 Watts of RF power in the cellular communications bands. Users must take precautions to minimize exposure to these RF fields:

Warning

Always terminate the PIM output port of the test equipment into a load, a loaded line or a line that will radiate or absorb the energy before beginning a PIM test.

Confirm that the PIM Master RF power is off after a PIM test.

Always confirm that the PIM RF power is off before disconnecting a coaxial connection, otherwise RF burns may result. Immediate burns to fingers or eyes can result from exposure to live connectors.

Ensure all antenna's under test are placed so that no personnel are exposed to RF levels that exceed the maximum allowable exposure.

The commands in this chapter are functional in all PIM Master modes of operation.

3-1 :FETCh:GPS Subsystem

The commands in this subsystem return the most recent measured GPS data.

Fetch GPS Fix Data

:FETCh:GPS?

Description: Returns the most recent GPS fix information from the optional GPS receiver.

The results are returned as a set of comma-delimited values in the following format:

<fix status>, <date/time>, <latitude>, <longitude>

The <fix status> field is either "GOOD FIX" or "NO FIX" depending on whether the GPS receiver is currently calculating position data. If "NO FIX" is the value of the <fix status> field, then no data follows.

The date and time (<date/time> field) are returned in the following format:

Www Mmm dd hh:mm:ss yyyy

Where *Www* is the weekday in letters, *Mmm* is the month in letters, *dd* is the day of the month, *hh:mm:ss* is the time (24-hour time), and *yyyy* is the year.

Both <latitude> and <longitude> fields are expressed in radians. A negative latitude value corresponds to a "south" reading. A negative longitude value corresponds to a "west" reading.

Requires Option 31.

Syntax: :FETCh:GPS?

Cmd Parameters: NA (query only)

Query Responses: <string>, <arg>, <NR2>, <NR2> for parameter data of <fix status>, <date/time>, <latitude>, <longitude>

Default Unit: Radians

Front Panel

Access: NA

3-2 :INSTRUMENT Subsystem

One instrument may contain many logical instrument “modes”. This subsystem controls the selection of the current instrument mode.

:INSTRUMENT:CATALOG:FULL?

Title: Query Available Modes

Description: Returns a comma-separated list of available modes. Mode names are enclosed in double quotes (“”). Immediately following the string name is the application number. For example, an instrument with the High Accuracy Power Meter (Option 19) would return the string: “HI_PM”10,”MINIPIM”46. And an instrument with the Site Master Option 331 and the High Accuracy Power Meter (Option 19) would return the string: “VNA”2,”HI_PM”10,”MINIPIM”46.

Front Panel

Access: **Shift-Mode (9)**, or **Menu**

:INSTRUMENT:NSELECT <integer>

:INSTRUMENT:NSELECT?

Title: Select Mode by Number

Description: Sets the instrument mode based on the value of <integer>. The query version returns the number associated with the current mode. Use :INSTRUMENT:CATALOG:FULL? to get a list of available mode names and their integer representations.

Parameter: <integer>

Parameter Type: <integer>

Related Command: :INSTRUMENT:CATALOG:FULL?

:INITIATE:CONTINUOUS

:INSTRUMENT[:SELECT]

:STATUS:OPERATION?

Front Panel

Access: **Shift-Mode (9)**, or **Menu**

Note

Switching modes can take longer than 80 seconds, depending on the application. Add a delay of at least 90 seconds between mode switch commands. Anritsu Company advises you to set the remote PC time-out to 120 seconds in order to avoid unexpected time-out errors.

:INSTRUMENT[:SELECT] <string>

:INSTRUMENT[:SELECT]?

Title: Select Mode by Name

Description: Sets the instrument mode based on the mode name specified by <string>. Enclose the <string> argument in single or double quotes. The query version returns the name of the current mode. Use :INSTRUMENT:CATALOG:FULL? to get a list of available modes.

Parameter: <string>

Related Command: :INSTRUMENT:CATALOG:FULL?

:INSTRUMENT:NSELECT

Front Panel

Access: **Shift-Mode (9)**, or **Menu**

Note

Switching modes can take longer than 80 seconds, depending on the application. Add a delay of at least 90 seconds between mode switch commands. Anritsu Company advises you to set the remote PC time-out to 120 seconds in order to avoid unexpected time-out errors.

3-3 :MMEMory Subsystem

The Mass MEMory subsystem contains functions that provide access to the instrument's setup and data storage.

:MMEMory:DATA? <file name>

Title: Transfer Data

Description: Transfers the data stored in the given file from the instrument to the controlling program. This is a query only. Data is transferred in the form of <header><block>. The ASCII <header> specifies the number of data bytes. It looks like #AX, where A is the number of digits in X and X is the number of bytes in <block>. <file name> should be enclosed in either single quotes (') or double quotes (" ") and should contain a file extension (for example, .stp, .jpg), and the file must not be larger than 262136 bytes. Use the command MMEMory:MSIS to set the current storage location.

Parameter: <file name>

Front Panel

Access: **NA**

:MMEMory:MSIS INTernal | USB

:MMEMory:MSIS?

Title: Storage Location

Description: Sets the storage location. Setting the storage location to INTernal will set the current storage location to be the internal memory. Setting the storage location to USB will set the current storage location to be the USB Flash drive. Note that the storage location can be set independently and can be different for remote operation and front panel operation. Changing the copy location remotely does not change the location that is set and displayed on the front panel. Similarly, changing the copy location via the front panel does not affect the location that is used by the remote operation commands.

Note that the storage location must be available in order for it to be set. Also note that the command will always succeed even if the external memory device is not present.

Parameter: INTernal | USB

Parameter Type: <char>

Related Command: :MMEMory:MSIS:DESTination

:MMEMory:MSIS:COPY

Title: Copy From Current Location To Destination

Description: Copies all measurements, setups, and JPEG files that are stored in the current storage location to the “copy to destination” location.

Related Command: :MMEMory:MSIS
:MMEMory:MSIS:DESTination

Front Panel

Access: **Shift-File (7)**, Copy

:MMEMory:MSIS:DESTination INTernal | USB
:MMEMory:MSIS:DESTination?

Title: Copy to Destination

Description: Sets the destination to which measurements and setups in the current storage location are copied. Setting the location to `INTernal` copies the files that are stored at the current storage location into the internal memory when the command `:MEMMory:MSIS:COPY` is sent.

Setting the location to `USB` copies the files that are stored at the current storage location into the USB Flash drive when the command `:MMEM:MSIS:COPY` is sent.

Note that the storage location can be set independently and can be different for remote operation and front panel operation. Changing the save location remotely does not change the location that is set and displayed on the front panel. Similarly, changing the save location via the front panel does not affect the location that is used by the remote operation commands. Also note that the command will always succeed even if the external memory device is not present.

Parameter: `INTernal | USB`

Related Command: `:MMEMory:MSIS`
`:MMEMory:MSIS:COPY`

Front Panel

Access: **Shift-File (7)**, Save (or Save Measurement), Change Save Location

:MMEMory:STORe:JPEG <file name>

Title: Save Screen as JPEG

Description: Saves the current screen measurement as a JPEG file. This will save the screen as a JPEG file specified by `<file name>` with the extension `.jpg` to the current storage location. `<file name>` should be enclosed in either single quotes (`'`) or double quotes (`"`) and should not contain a file extension. Use the command `MMEMory:MSIS` to set the current storage location.

Parameter: `<file name>`

Example: To save the screen into the file name "trace":
`:MMEMory:STORe:JPEG "trace"`

Related Command: `:MMEMory:DATA?`
`:MMEMory:MSIS INTernal | USB`

Front Panel

Access: **Shift-File (7)**, Save

3-4 [:SENSE]:GPS Subsystem

This subsystem contains commands that relate to the optional GPS (Global Positioning System) on the instrument.

GPS On/Off

[:SENSE]:GPS

[:SENSE]:GPS?

Description: Enables/disables optional GPS capability. The query version returns 0 when the GPS is Off and returns 1 when the GPS is On.

Requires Option 31.

Syntax: [:SENSE]:GPS OFF|ON|0|1
[:SENSE]:GPS?

Cmd Parameters: <boolean> OFF|ON|0|1

Query Responses: <bNR1> 0|1

Default Value: Off

Front Panel

Access: **Shift 8** (System), GPS, GPS On/Off

GPS Reset

[:SENSE]:GPS:RESet

Description: Resets optional GPS receiver.

Requires Option 31.

Syntax: [:SENSE]:GPS:RESet

Cmd Parameters: NA

Query Responses: NA (no query)

Front Panel

Access: **Shift 8** (System), GPS, Reset

GPS Antenna Current

[:SENSE]:GPS:CURREnt?

Description: Query only. Reads the current draw of the GPS antenna in mA.

Requires Option 31.

Syntax: [:SENSE]:GPS:CURREnt?

Cmd Parameters: NA (query only)

Query Responses: <integer>

Front Panel

Access: **Shift 8** (System), GPS, GPS Info

GPS Antenna Voltage

[:SENSE]:GPS:VOLTage 0|1

[:SENSE]:GPS:VOLTage?

Description: Sets and Reads the voltage setting for the GPS antenna. To set the voltage to 3.3 V, send the 0 parameter after the command. To set the voltage to 5 V, send the 1 parameter after the command. The query version returns 0 for an antenna voltage of 3.3 V and returns 1 for an antenna voltage of 5 V.

Requires Option 31.

Syntax: [:SENSE]:GPS:VOLTage 0|1
[:SENSE]:GPS:VOLTage?

Cmd Parameters: <boolean> 0|1

Query Responses: <bNR1> 0|1

Front Panel

Access: **Shift 8** (System), GPS, GPS Voltage
Shift 8 (System), GPS, GPS Info

3-5 :SYSTEM Subsystem

This subsystem contains commands that affect instrument functionality that does not directly relate to data collection, display, or transfer.

:SYSTEM:OPTions?

Title: Query Installed Options

Description: Returns a string of the installed options. Options are separated by a "/". The string will return "NONE" if no options are installed.

Related Command: *IDN?

Front Panel

Access: **NA**

:SYSTEM:PRESet

Title: Preset

Description: This command restores all application parameters to their factory preset values. This does not modify system parameters such as language, volume, or brightness.

Front Panel

Access: **Shift-Preset (1), Preset**

Chapter 4 — PIM Analyzer

Programming Commands

The Anritsu PIM Master is capable of producing 80 Watts of RF power in the cellular communications bands. Users must take precautions to minimize exposure to these RF fields:

Warning

Always terminate the PIM output port of the test equipment into a load, a loaded line or a line that will radiate or absorb the energy before beginning a PIM test.

Confirm that the PIM Master RF power is off after a PIM test.

Always confirm that the PIM RF power is off before disconnecting a coaxial connection, otherwise RF burns may result. Immediate burns to fingers or eyes can result from exposure to live connectors.

Ensure all antenna's under test are placed so that no personnel are exposed to RF levels that exceed the maximum allowable exposure.

4-1 SCPI Commands Introduction

The set of commands in this chapter are used to prepare the PIM Master hardware for the selected measurements. These commands activate a specified measurement and set the instrument to a wait-for-sweep mode, waiting for an `:INITiate` command to begin a measurement. Ensure that your PIM Master is in the desired testing Mode before sending SCPI commands.

Example:

A typical command set for the PIM Master would include:

```
SENSe:PIManalyzer:MODE PIM|PIMSwp|DTP  
(Sets mode to PIM vs. Time, Swept PIM, or DTP)
```

```
SENSe:PIManalyzer:MODE?  
(Responds with PIM|PIMSwp|DTP, mode type PIM vs. Time, Swept PIM, or DTP)
```

```
[SENSe]:PIManalyzer:FREQuency:F1 1930000000 (Sets F1 to 1930 MHz)
```

```
[SENSe]:PIManalyzer:FREQuency:F2 1990000000 (Sets F2 to 1990 MHz)
```

```
[SENSe]:PIManalyzer:AUTorange 1 (Sets Amplitude to Auto Range)
```

```
[SENSe]:PIManalyzer:IMD:ORDer 3 (Sets center frequency of Rx to IM3)
```

```
[SENSe]:PIManalyzer:OUTPut:POWer 20 (Sets power to 20 Watts)
```

```
[SENSe]:PIManalyzer:TEST:DURation 10 (Sets the POWER ON time)
```

```
INITiate:PIManalyzer:MEASure ON (Starts PIM measurement)
```

4-2 :CALCulate Subsystem

The commands in this subsystem process data that has been collected via the SENSE subsystem.

:CALCulate:DTPMeas:CABLoss

:CALCulate:DTPMeas:CABLoss?

Title: DTP cable loss

Description: Sets and queries DTP cable loss in dB/current distance unit.

Parameter: Cable loss in units of dB/distance

Parameter range is 0 dB/ft to 5 dB/ft (0 dB/m to 16.404 dB/m).

Default Value: None. If no value is sent, then no action occurs. To verify that a value has been received, follow the command with a query.

Example: To set the cable loss to 0.1 dB/ft:

```
:CALCulate:DTPMeas:CABLoss 0.1
```

To query the cable loss:

```
:CALC:DTPM:CABL?
```

Front Panel

Access: **Distance**, More, Cable Loss

:CALCulate:DTPMeas:DISPlay:RESOLution

:CALCulate:DTPMeas:DISPlay:RESOLution?

Title: DTP data points

Description: Sets and queries DTP data points.

Parameter: 128, 255

Default Value: None. If no value is sent, then no action occurs. To verify that a value has been received, follow the command with a query.

Example: To set the data point to 128:

```
:CALCulate:DTPMeas:DISPlay:RESOLution 128
```

To query the data point setting:

```
:CALC:DTPM:DISP:RESO?
```

Front Panel

Access: **Distance**, DTP Aid, Data Points

:CALCulate:DTPMeas:DMAX?

Title: DTP maximum measurable distance

Description: Queries DTP maximum measurable distance in current distance unit.

Parameter: None

Default Value: None

Example: To query the DTP maximum measurable distance:

:CALC:DTPM:DMAX?

Related Command: :CALCulate:DTPMeas:START | STOP

:CALC:DTPM:STAR | STOP?

Front Panel

Access: **Distance**, DTP Aid, Stop Distance (Dmax)

:CALCulate:DTPMeas:FRESolution?

Title: DTP fault resolution

Description: Queries DTP fault resolution in current distance unit.

Parameter: None

Default Value: None

Example: To query the DTP fault resolution:

:CALC:DTPM:FRES?

Front Panel

Access: **NA**

:CALCulate:DTPMeas:PVELOCITY
:CALCulate:DTPMeas:PVELOCITY?

Title: DTP cable propagation velocity index

Description: Sets and queries DTP cable propagation velocity index.

Parameter: 0.1 to 1.0

Default Value: None. If no value is sent, then no action occurs. To verify that a value has been received, follow the command with a query.

Example: To set the cable propagation velocity index to 0.75:

```
:CALCulate:DTPMeas:PVELOCITY 0.75
```

To query the cable propagation velocity index:

```
:CALC:DTPM:PVEL?
```

Front Panel

Access: **Distance**, DTP Aid, Propagation Velocity

:CALCulate:DTPMeas:REFERENCE:AMPLITUDE
:CALCulate:DTPMeas:REFERENCE:AMPLITUDE?

Title: DTP Reference Line Amplitude

Description: Sets and queries the amplitude of the reference line in DTP mode in the current units (dBm by default).

Parameter: 0 to -260

Parameter Type: <float>

Default Value: None. If no value is sent, then no action occurs. To verify that a value has been received, follow the command with a query.

Example: To set the reference line to -100 dBm:

```
:CALCulate:DTPMeas:REFERENCE:AMPLITUDE -100
```

To query the reference line amplitude:

```
:CALC:DTPM:REF:AMPL?
```

Front Panel

Access: **Shift-Limit (6)**, Amplitude

:CALCulate:DTPMeas:REfERENCE[:STATe] OFF|ON|0|1
:CALCulate:DTPMeas:REfERENCE[:STATe]?

Title: DTP Reference Line State

Description: Turns the reference line ON or OFF. If the value is set to ON or to 1, then the reference line is ON. If the value is set to OFF or to 0, then the reference line is OFF. The query version of the command returns a 1 if the reference line is ON and returns a 0 if it is OFF.

Parameter: OFF|ON|0|1

Parameter Type: <boolean>

Default Value: None

Example: To turn On the reference line:

```
:CALCulate:DTPMeas:REfERENCE ON
```

```
:CALCulate:DTPMeas:REfERENCE:STATe ON
```

```
:CALCulate:DTPMeas:REfERENCE:STATe 1
```

To turn Off the reference line:

```
:CALCulate:DTPMeas:REfERENCE OFF
```

```
:CALCulate:DTPMeas:REfERENCE:STATe 0
```

```
:CALCulate:DTPMeas:REfERENCE 0
```

To query the reference line state:

```
:CALC:DTPM:REF?
```

```
:CALC:DTPM:REF:STAT?
```

Front Panel

Access: **Shift-Limit (6)**, On/Off

:CALCulate:DTPMeas:START
:CALCulate:DTPMeas:START?

Title: DTP Distance Start Setup

Description: Sets and queries DTP distance start. Parameters are *m* for meters and *ft* for feet.

Parameter: *m|ft*

Default Value: Values in meters

Example: To set the DTP start distance to 10 feet:

```
:CALCulate:DTPMeas:START 10 ft
```

To query the DTP start distance:

```
:CALC:DTPM:STAR?
```

Related Command: `:CALCulate:DTPMeas:STOP 100 ft`

```
:CALC:DTPM:STOP?
```

```
:CALCulate:DTPMeas:DMAX?
```

```
:CALC:DTPM:DMAX?
```

Front Panel

Access: **Distance**, DTP Aid, Start Distance

:CALCulate:DTPMeas:STOP
:CALCulate:DTPMeas:STOP?

Title: DTP Distance Stop Setup

Description: Sets and queries DTP distance stop. Parameters are *m* for meters and *ft* for feet.

Parameter: *m|ft*

Default Value: Values in meters

Example: To set the DTP stop distance to 100 feet:

```
:CALCulate:DTPMeas:START 100 ft
```

To query the DTP stop distance:

```
:CALC:DTPM:STOP?
```

Related Command: `:CALCulate:DTPMeas:START 10 ft`

```
:CALC:DTPM:STAR?
```

```
:CALCulate:DTPMeas:DMAX?
```

```
:CALC:DTPM:DMAX?
```

Front Panel

Access: **Distance**, DTP Aid, Stop Distance

:CALCulate:DTPMeas:UNIT METers | FEET

:CALCulate:DTPMeas:UNIT?

Title: DTP distance unit

Description: Sets and queries DTP distance unit. Parameters are m for meters and ft for feet.

Parameter: METers | FEET

Default Value: None. If no value is sent, then no action occurs. To verify that a value has been received, follow the command with a query.

Example: To set the unit to meter:

```
:CALCulate:DTPMeas:UNIT METers
```

```
:CALC:DTPM:UNIT MET
```

To query the distance unit:

```
:CALC:DTPM:UNIT?
```

Front Panel

Access: **Distance**, Units

:CALCulate:DTPMeas:WINDow

:CALCulate:DTPMeas:WINDow?

Title: DTP Windowing

Description: Sets and queries the type of windowing in order of increasing side lobe reduction. Windowing settings are: rectangular, nominal side lobe, low side lobe, and minimum side lobe.

Parameter: RECTangular = Rectangular Windowing

NSLobe = Nominal Side Lobe Windowing

LSLobe = Low Side Lobe Windowing

MSLobe = Minimum Side Lobe Windowing

Default Value: None. If no value is sent, then no action occurs. To verify that a value has been received, follow the command with a query.

Example: To set the Nominal Side Lobe Windowing:

```
:CALCulate:DTPMeas:WINDow NSLobe
```

To query the type of Windowing:

```
:CALC:DTPM:WIND?
```

Front Panel

Access: **Distance**, More, Window

:CALCulate:LIMit:ALARm ON|OFF|0|1

:CALCulate:LIMit:ALARm?

Title: Upper Limit Alarm On/Off

Description: Sets and queries limit alarm for PIM vs. Time and Swept PIM measurement types. This alarm is associated only to the upper limit. Lower limit does not have an associated alarm.

Parameter: Limit Alarm ON|OFF|0|1 (0 = On, 1 = Off)

Parameter Type: <boolean>

Default Value: Off

Example: To set the limit alarm:

```
:CALCulate:LIMit:ALARm 0
```

To query the limit alarm:

```
:CALC:LIM:ALAR?
```

Front Panel

Access: **Shift-Limit (6)**, Limit Alarm

:CALCulate:LIMit:AMPLitude

:CALCulate:LIMit:AMPLitude?

Title: Set Limit Amplitude

Description: Sets and queries limit amplitude for PIM vs. Time and Swept PIM measurement types. The amplitude will be associated with the currently selected limit (upper/lower). The amplitude reference level range is -50 dBm to -140 dBm. The upper and lower limits can be set far beyond the reference level range, but such settings are of no practical value.

Parameter: Magnitude (dBm)

Resolution: 0.1 dB

Default Value: None. If no value is sent, then no action occurs. To verify that a value has been received, follow the command with a query.

Example: To set the limit amplitude to -120 dBm:

```
:CALCulate:LIMit:AMPLitude -120
```

To query the limit amplitude:

```
:CALC:LIM:AMPL?
```

Front Panel

Access: **Shift-Limit (6)**, Limit Move, Amplitude

:CALCulate:LIMit:FAIL?

Title: Upper Limit Fail Check

Description: Checks if current trace data is failing Upper Limit dBm setting. If one or more trace points fail, then the condition would indicate fail for a response.

Parameter: 0/1 for Pass/Fail

Default Value: None

Example: To query if the current trace data is failing Upper Limit dBm setting:
:CALC:LIM:FAIL?

Front Panel

Access: **NA**, no direct access

Adjusting Limit Amplitude shows a number display change to red when the limit line falls below the highest trace data point.

:CALCulate:LIMit[:STATe] OFF|ON|0|1**:CALCulate:LIMit[:STATe]?**

Title: Limit State

Description: Turns the limit line ON or OFF. If the value is set to ON or to 1, then the currently selected limit line is ON. If the value is set to OFF or to 0, then the currently selected limit line is OFF. The query version of the command returns a 1 if the currently selected limit line is ON and returns a 0 if it is OFF.

Parameter: OFF|ON|0|1

Parameter Type: <boolean>

Default Value: OFF

Example: To turn on the limit line:

```
:CALCulate:LIMit ON
:CALCulate:LIMit:STATe ON
:CALCulate:LIMit:STATe 1
```

To turn off the limit line:

```
:CALCulate:LIMit OFF
:CALCulate:LIMit:STATe 0
:CALCulate:LIMit 0
```

To query the limit line state:

```
:CALCul:LIM?
:CALC:LIM:STAT?
```

Front Panel

Access: **Shift-Limit (6)**, Limit On/Off

:CALCulate:LIMit:TYPE**:CALCulate:LIMit:TYPE?**

Title: Limit Type Selection

Description: Sets and queries limits for PIM vs. Time and Swept PIM measurement types. Selections are Upper/Lower.

Parameter: Limit value (0 = Upper, 1 = Lower)

Default Value: None. If no value is sent, then no action occurs. To verify that a value has been received, follow the command with a query.

Example: To set the upper limit:

```
:CALCulate:LIMit:TYPE 0
```

To query the limit type:

```
:CALC:LIM:TYPE?
```

Front Panel

Access: **Shift-Limit (6)**, Limit

:CALCulate:LIMit:VALue

Title: Limit Value Magnitude Change

Description: Adds a magnitude change to the existing limit magnitude for PIM vs. Time and Swept PIM measurement types.

Parameter: Magnitude (dB)

Resolution: 0.1 dB

Default Value: None

Example: To decrease the currently selected limit magnitude by 5 dB:

```
:CALCulate:LIMit:VALue -5
```

Related Command: To query the limit amplitude:

```
:CALC:LIM:AMPL?
```

Front Panel

Access: **Shift-Limit (6)**, Limit Move, Move Limit U/D

:CALCulate:MARKer:AOFF

Title: Turn All Markers Off

Description: Turns off all markers

Example: To turn Off all markers:

```
:CALC:MARK:AOFF
```

Front Panel

Access: **Marker**, All Markers Off

```
:CALCulate:MARKer{1|2|3|4|5|6}:DELTA[:STATe] OFF|ON|0|1
:CALCulate:MARKer{1|2|3|4|5|6}:DELTA[:STATe]?
```

Title: Delta Marker State

Description: Sets the specified delta marker on or off. The query returns the state of the specified delta marker (0|1)

Parameter: OFF|ON|0|1

Parameter Type: <boolean>

Default Value: OFF

Example: To turn on the delta marker #3:

```
:CALCulate:MARKer3:DELTA ON
:CALCulate:MARKer3:DELTA 1
:CALCulate:MARKer3:DELTA:STATe ON
:CALCulate:MARKer3:DELTA:STATe 1
```

To turn off delta marker #6:

```
:CALCulate:MARKer6:DELTA OFF
:CALCulate:MARKer6:DELTA:STATe OFF
:CALCulate:MARKer6:DELTA:STATe 0
```

To query the state of delta marker #2:

```
:CALC:MARK2:DELT?
:CALC:MARK2:DELT:STAT?
```

Front Panel

Access: **Marker**, Delta On Off

```
:CALCulate:MARKer{1|2|3|4|5|6}:DELTA:TRACe 0|1
:CALCulate:MARKer{1|2|3|4|5|6}:DELTA:TRACe?
```

Title: Delta Marker Trace

Description: Sets the specified delta marker to a desired trace. Valid only for Swept PIM mode.

Parameter: 0|1

Default Value: None. If no value is sent, then no action occurs. To verify that a value has been received, follow the command with a query.

Example: To set delta marker #1 onto the fixed F2 sweep (Sweep #2):

```
:CALCulate:MARKer1:DELTA:TRACe 1
```

To set delta marker #2 onto the fixed F1 sweep (Sweep #1):

```
:CALC:MARK2:DELTA:TRAC 0
```

To query which trace delta marker #6 is on:

```
:CALC:MARK6:DELTA:TRAC?
```

Front Panel

Access: **Marker**, Marker, M#, Delta, Swap Marker Trace

```
:CALCulate:MARKer{1|2|3|4|5|6}:DELTA:X <x-parameter>
:CALCulate:MARKer{1|2|3|4|5|6}:DELTA:X?
```

Title: Delta Marker X Value

Description: Sets the location of the delta marker on the x-axis at the specified location <x-parameter> + the reference marker x-axis. <x-parameter> is defined in the current x-axis units. The query version of the command returns the location of the delta marker on the x-axis.

Parameter: <x-parameter>

Default Unit: Current x-axis unit

Example: If both the reference and delta marker #1 are currently at 1 GHz on the x-axis, then send the command below to set the delta marker #1 to 2 GHz on the x-axis:

```
:CALCulate:MARKer1:DELTA:X 1GHz
```

Related Command: :CALCulate:MARKer [1] | 2 | 3 | 4 | 5 | 6 :X

Front Panel

Access: **Marker**, [Marker 1/2/3/4/5/6], Delta On, **Arrow** buttons

:CALCulate:MARKer{1 | 2 | 3 | 4 | 5 | 6}:DELta:Y?

Title: Delta Marker Read Y Value

Description: Reads the current Y value for the specified delta marker. The units are the units of the y-axis.

Default Unit: Current y-axis unit

Example: To query the Y value of delta marker #6:

:CALC:MARK6:DELT:Y?

Front Panel

Access: **NA**

:CALCulate:MARKer{1 | 2 | 3 | 4 | 5 | 6}[:STATE] OFF|ON|0|1**:CALCulate:MARKer{1 | 2 | 3 | 4 | 5 | 6}[:STATE]?**

Title: Marker State

Description: Sets the specified marker on or off.

Parameter: OFF|ON|0|1

Parameter Type: <boolean>

Default Value: OFF

Example: To turn off reference marker #1:

:CALCulate:MARKer1:STATE OFF

To query the state of marker #6:

:CALC:MARK6:STAT?

Front Panel

Access: **Marker**, Marker, M#, On/Off

```
:CALCulate:MARKer{1|2|3|4|5|6}:TRACe 0|1  
:CALCulate:MARKer{1|2|3|4|5|6}:TRACe?
```

Title: Marker Trace

Description: Sets the specified marker to a desired trace. Valid only for Swept PIM mode.

Parameter: 0|1

Default Value: None. If no value is sent, then no action occurs. To verify that a value has been received, follow the command with a query.

Example: To set marker #1 onto the fixed F2 sweep (Sweep #2):

```
:CALCulate:MARKer1:TRACe 1
```

To set marker #2 onto the fixed F1 sweep (Sweep #1):

```
:CALC:MARK2:TRAC 0
```

To query which trace marker #6 is on:

```
:CALC:MARK6:TRAC?
```

Front Panel

Access: **Marker**, Marker, M#, Swap Marker Trace

:CALCulate:MARKer{1|2|3|4|5|6}:X <x-parameter>

:CALCulate:MARKer{1|2|3|4|5|6}:X?

Title: Marker X Value

Description: Sets the location of the marker on the x-axis at the specified location. <x-parameter> is defined in the current x-axis units. The query version of the command returns the location of the marker on the x-axis. Note that the marker is snapped to the data point closest to the specified value. If the specified marker is not On, then it is set to On. In Swept PIM, Marker 1 is always On, but remains at trace peak and cannot be moved. The query command reports the x-axis position for Swept PIM.

Parameter: <x-parameter>

Default Unit: seconds in PIM versus Time measurement type
meters or feet in DTP measurement type
hertz in Swept PIM measurement type (query only)

Example: (In PIM vs. Time, DTP, or Swept PIM) To query the X value of reference marker #3:

```
:CALC:MARK3:X?
```

(In PIM vs. Time) To set reference marker #3 to 1.5 seconds on the x-axis:

```
:CALCulate:MARKer3:X 1.5
:CALCulate:MARKer3:X 1.5s
```

(In PIM vs. Time) To set reference marker #1 to 25 μ s:

```
:CALCulate:MARKer:X 25
:CALCulate:MARKer1:X 25 $\mu$ s
```

(In DTP) To set reference marker #1 to 15 ft on the x-axis:

```
:CALCulate:MARKer:X 15
:CALCulate:MARKer1:X 15ft
```

To query the location of the marker on the x-axis:

```
:CALC:MARK:X?
```

Front Panel

Access: **Marker**, [Marker 1/2/3/4/5/6]

:CALCulate:MARKer{1|2|3|4|5|6}:Y?

Title: Marker Read Y Value

Description: Reads the current Y value for the specified marker. The units are the units of the y-axis.

Default Unit: Current y-axis unit

Example: To query the Y value of reference marker #4:

```
:CALC:MARK4:Y?
```

Front Panel

Access: **NA**

:CALCulate:SCALE:UNIT DBM|DBC**:CALCulate:SCALE:UNIT?**

Title: Scale Unit

Description: Sets and queries the scale unit for PIM vs. Time, Distance-to-PIM, and Swept PIM.

Parameter: DBM|DBC

Default Value: None. If no value is sent, then no action occurs. To verify that a value has been received, follow the command with a query.

Example: To set the unit to dBm:

```
:CALCulate:SCALE:UNIT DBM
```

```
:CALC:SCAL:UNIT DBM
```

To query the scale unit:

```
:CALC:SCAL:UNIT?
```

Front Panel

Access: **Amplitude, Units**

:CALCulate:SPECTrum:MAXHold
:CALCulate:SPECTrum:MAXHold?

Title: Spectrum View Max Hold

Description: Enables or disables Max Hold for Spectrum View mode.

Parameter: OFF|ON|0|1

Parameter Type: <boolean>

Default Value: None. If no value is sent, then no action occurs. To verify that a value has been received, follow the command with a query.

Example: To enable Max Hold:

```
CALCulate:SPECTrum:MAXHold ON
```

To query the state of Max Hold:

```
CALC:SPEC:MAXH?
```

Front Panel

Access: In Spectrum View mode

Measurements, Max Hold or Shift-5 (Trace), Max Hold.

4-3 :CALibration Subsystem

The commands in this subsystem control the system calibration.

:CALibration:PIManalyzer:FULL

:CALibration:PIManalyzer:FULL?

Title: Full Calibration

Description: Sets or resets the calibration for the instrument. This calibration is done for all 3 measurement types at their current configuration (in other words, output power, frequency (PVT only), and IMD order for PVT and Swept PIM). The query returns 0 for “CAL OFF” or 1 for “CAL ON”.

Parameter: OFF | ON | 0 | 1

Parameter Type: <boolean>

Default Value: None

Example: To start full calibration:

```
:CALibration:PIManalyzer:FULL ON
```

To query the calibration state:

```
:CAL:PIM:FULL?
```

Front Panel

Access: **Shift-Cal (2)**, Start Calibration

Shift-Cal (2), Reset Calibration

4-4 :DISPlay Subsystem

The commands in this subsystem control parameters in the measurement display (the sweep window).

:DISPlay:WINDow:Trace:Y[:SCALE]:PDIVision

:DISPlay:WINDow:Trace:Y[:SCALE]:PDIVision?

Title: PIM vs. Time and Swept PIM Scale (Not for DTP)

Description: Sets and queries Scale.

Parameter: Amplitude in dB/div

Default Value: 10 dB/div

Range: 1 dB/div to 15 dB/div

Example: To set PIM vs. Time or Swept PIM scale to 5 dB/div:

```
:DISPlay:WINDow:TRAcE:Y[:SCALE]:PDIVision 5
```

Front Panel

Access: **Amplitude**, Scale

:DISPlay:WINDow:Trace:Y[:SCALE]:RLEVEL

:DISPlay:WINDow:Trace:Y[:SCALE]:RLEVEL?

Title: PIM vs. Time and Swept PIM Reference Level (Not for DTP)

Description: Sets and queries Reference Level.

Parameter: Amplitude in dBm

Default Value: -70 dBm

Range: -160 dBm to -50 dBm in 0.1 dB increments

Example: To set PIM vs. Time or Swept PIM reference level to -60 dBm:

```
:DISPlay:WINDow:TRAcE:Y[:SCALE]:RLEVEL -60
```

Front Panel

Access: **Amplitude**, Reference Level

4-5 :INITiate Subsystem

The commands in this subsystem control the triggering of measurements.

:INITiate:PIManalyzer:MEASure OFF|ON|0|1

Title: Trigger PIM Analyzer Measurement

Description: This command triggers the start of the PIM Master measurement to measure intermodulation distortion generated between the PIM Analyzer and the system under test. It works with any of the available measurement types: PIM vs. Time, DTP, Swept PIM. The measurement will continue until the defined test duration time has elapsed.

Sending this command with the OFF parameter or the 0 parameter cancels the measurement.

Parameter: OFF|ON|0|1

Parameter Type: <boolean>

Front Panel

Access: **Measurements**, Test (Measure underlined)

:INITiate:PIManalyzer:PVT:ALLPower:CAL

Title: PvT All Power Levels Calibration

Description: This command triggers the start of the PIM vs. Time calibration for all power levels.

Front Panel

Access: **Shift-Cal (2)**, Custom Calibrations, Start Cal

(full name: Start Cal PIM vs. Time Only All Power Levels)

:INITiate:PIManalyzer:RESidual:CAL

Title: PIM Calibration: Current Mode Only

Description: This command triggers the start of the calibration for current measurement mode only.

Front Panel

Access: **None**

4-6 :MMEMory Subsystem

The commands in the Mass MEMory subsystem contain functions that provide access to the setup and data storage of the instrument.

:MMEMory:CABLeList:RESet

Title: Reset Cable List to Default

Description: Clears the Cable List favorites and restores the factory-default cable list information.

Front Panel

Access: **Distance**, More, Cable, Clear all Favorites

:MMEMory:LOAD:TRACe <integer>,<file name>

Title: Recall Measurement

Description: The instrument must be in the mode of the saved trace in order to recall that trace. Use :INSTRument:SElect or :INSTRument:NSElect to set the mode. Recalls a previously stored measurement trace from the current storage location. The saved measurement trace to be loaded is specified by <file name>. <file name> should be enclosed in either single quotes (' ') or double quotes (" ") and should contain a file extension. Note that the trace specified by <file name> should be available at the current mass storage location. Use the command :MMEMory:MSIS to set the current mass storage location. The <integer> parameter is not currently used, but it must be sent. Send a 1.

File name extensions: ".pim" for PIM Analyzer

Note: Extensions not available for T1 and HI_PM.

Parameter: <integer>, <file name>

Example: To recall trace with file name "trace":
:MMEMory:LOAD:TRACe 1,"trace.pim"

Related Command: :MMEMory:STORe:TRACe
:MMEMory:MSIS INTernal|USB

Front Panel

Access: **Shift-File (7)**, Recall Measurement

:MMEMory:STORe:TRACe <integer>,<file name>

Title: Save Measurement

Description: Stores the trace into the file specified by <file name>. <file name> should be enclosed in either single quotes (' ') or double quotes (" ") and should not contain a file extension. Use the command :MMEMory:MSIS to set the current storage location. The <integer> parameter is not currently used, but it must be sent. Send a 0.

Parameter: <integer>, <file name>

Example: To save the trace into the file name "trace":

```
:MMEMory:STORe:TRACe 0,"trace"
```

Related Command: :MMEMory:LOAD:TRACe
:MMEMory:MSIS INTernal|USB

Front Panel

Access: **Shift-File (7)**, Save Measurement

:MMEMory:LOAD:STATe <integer>,<file name>

Title: Recall Setup

Description: Recalls a previously stored instrument setup in the current storage location. The setup file to be loaded is specified by <file name>. <file name> should be enclosed in either single quotes (' ') or double quotes (" ") and should contain a file extension ".stp". Use the command :MMEMory:MSIS to set the current storage location. The <integer> parameter is not currently used, but it must be sent. Send a 1.

Parameter: <integer>, <file name>

Example: To recall a previously stored instrument setup:

```
:MMEMory:LOAD:STATe 1,"setup.stp"
```

Related Command: :MMEMory:STORe:STATe
:MMEMory:MSIS INTernal|USB

Front Panel

Access: **Shift-File (7)**, Recall, (select Setup from list)

:MMEMory:STORe:STATe <integer>,<file name>

Title: Save Setup

Description: Stores the current setup into the file specified by <file name>. <file name> should be enclosed in either single quotes (' ') or double quotes (" ") and should not contain a file extension ".stp". Use the command :MMEMory:MSIS to set the current storage location. The <integer> parameter is not currently used, but it must be sent. Send a 0.

Parameter: <integer>, <file name>

Example: To save the current instrument setup:
:MMEMory:STORe:STATe 0,"setup"

Related Command: :MMEMory:LOAD:STATe
:MMEMory:MSIS INTernal|USB

Front Panel

Access: **Shift-File (7)**, Save, Change Type, (select Setup from list)

4-7 :SENSe Subsystem

The commands in this subsystem relate to device-specific parameters, not signal-oriented parameters.

[:SENSe] :DTPMeas :AVERage :TYPE

[:SENSe] :DTPMeas :AVERage :TYPE?

Title: DTP Trace Mode

Description: Sets and queries DTP trace mode

Parameter: NORMAl = normal

MAXHold = max trace hold

Default Value: None. If no value is sent, then no action occurs. To verify that a value has been received, follow the command with a query.

Example: To set DTP trace mode to normal:

```
:SENSe:DTPMeas:AVERage:TYPE NORMAl
```

Front Panel

Access: **Setup**, Normal -> A / Max Hold -> A

[:SENSe] :DTPMeas :DISPlay :BOTTom

[:SENSe] :DTPMeas :DISPlay :BOTTom?

Title: DTP Display Bottom

Description: Sets and queries DTP display magnitude in the current units (dBm by default).

Parameter: Bottom magnitude

Range: Bottom = -260 (top = 0)

Default Value: None. If no value is sent, then no action occurs. To verify that a value has been received, follow the command with a query.

Example: To set the DTP display bottom to -100 dBm:

```
:SENSe:DTPMeas:DISPlay:BOTTom -100.0
```

Related Command: :SENSe:DTPMeas:DISPlay:TOP -15.0

```
:SENS:DTPM:DISP:TOP?
```

Front Panel

Access: **Amplitude**, Bottom

[:SENSe] :DTPMeas:DISPlay:TOP
[:SENSe] :DTPMeas:DISPlay:TOP?

Title: DTP Display Top

Description: Sets and queries DTP display magnitude in the current units (dBm by default).

Parameter: Top magnitude

Range: Top = 0 (bottom = -260)

Default Value: None. If no value is sent, then no action occurs. To verify that a value has been received, follow the command with a query.

Example: To set the DTP display top to -10 dBm:

```
:SENSe:DTPMeas:DISPlay:TOP -10.0
```

Related Command: :SENSe:DTPMeas:DISPlay:BOTTom -90.0
 :SENS:DTPM:DISP:BOTT?

Front Panel

Access: **Amplitude**, Top

[:SENSe] :DTPMeas:ENREsolution ON|OFF
[:SENSe] :DTPMeas:ENREsolution?

Title: PIM Master Enhanced Resolution

Description: This feature estimates the location of PIM sources on the measurement trace and displays up to 4 vertical impulse bars from bottom of measurement grid to point on measurement trace that indicates a predicted PIM source location. This is useful for resolving PIM sources that are physically close together.

Parameter: ON|OFF

Example: To set Enhanced Resolution to On:

```
:SENSe:DTPMeas:ENREsolution ON
```

Front Panel

Access: **Setup**, Enhanced Resolution

[:SENSe] :PIManalyzer:AVERaging FAST | LOWNoise
[:SENSe] :PIManalyzer:AVERaging?

Title: PIM vs. Time Trace Mode.

Description: Low Noise provides improvement in measurement range. Fast provides faster measurement updates (measurements per second). The query returns FAST or LOWN (LOWNoise).

Parameter: FAST | LOWNoise

Range: FAST, Averaging is minimum
LOWNoise, Averaging is maximum

Example: To set the PIM Master measurement for maximum averaging:
:SENSe:PIManalyzer:AVERaging LOWNoise

Front Panel

Access: **Setup**, Trace Mode

[:SENSe] :PIManalyzer:AUTorange OFF | ON | 0 | 1
[:SENSe] :PIManalyzer:AUTorange?

Title: PIM vs. Time Auto Range

Description: Sets and queries the Auto Range condition for PIM vs. Time measurement.

Parameter: None

Range: 0 | OFF, Auto Ranging is OFF
1 | ON, Auto Ranging is ON

Example: To set the PIM Master for Auto Range:
:SENSe:PIManalyzer:AUTorange 1

Front Panel

Access: **Amplitude**, Auto Range

[:SENSE] :PIMAnalyzer:DTPMeas:LRDTf [:STATE]
[:SENSE] :PIMAnalyzer:DTPMeas:LRDTf [:STATE] ?

Title: PIM Master Low Resolution DTF Sweep State

Description: Sets and queries whether a Low Resolution DTF sweep is performed during a Distance-To-PIM measurement.

Parameter: ON|OFF

Example: To enable the Low Resolution DTF sweep:

:SENSE:PIMAnalyzer:DTPMeas:LRDTf ON

To query whether the Low Resolution DTF sweep is enabled:

:PIM:DTPM:LRDT?

Front Panel

Access: **Setup**, Low Resolution DTF

[:SENSE] :PIMAnalyzer:DTPMeas:LRDTf:START?

Title: PIM Master Low Resolution DTF Sweep Start Frequency

Description: Queries the DTF Sweep Start Frequency in Hz.

Parameter: Frequency in Hz

Example: To get the DTF Sweep Start Frequency:

:PIM:DTPM:LRDT:STAR?

Related Command: :SENSE:PIMAnalyzer:DTPMeas:LRDTf:STOP?

:PIM:DTPM:LRDT:STOP?

Front Panel

Access: **NA**

[:SENSE] :PIMAnalyzer:DTPMeas:LRDTf:STOP?

Title: PIM Master Low Resolution DTF Sweep Stop Frequency

Description: Queries the DTF Sweep Stop Frequency in Hz.

Parameter: Frequency in Hz

Example: To get the DTF Sweep Stop Frequency:

:PIM:DTPM:LRDT:STOP?

Front Panel

Access: **NA**

```
[ :SENSE ] :PIManalyzer:FREQuency:F1 | 2
[ :SENSE ] :PIManalyzer:FREQuency:F1 | 2?
```

Title: PIM Master Frequency Setup

Description: Sets the PIM vs. Time carrier frequencies, calculates the IMx Order frequency, and sets the instrument to display the corresponding IMx frequency.

Parameter: Frequency in Hz

Default Unit: Hz

Ranges: PIM Master option dependent (for a list of ranges, refer to [Table B-1, “PIM Master Carrier Bands and Frequencies”](#) on page B-2)

Example: To set the PIM vs. Time frequency F2 for 1990 MHz:

```
:SENSE:PIManalyzer:FREQuency:F2 1990000000
```

To get the PIM vs. Time frequency F1:

```
PIM:FREQ:F1?
```

Front Panel

Access: **Freq**, Carrier F1|Carrier F2

```
[ :SENSE ] :PIManalyzer:FREQuency:STEP
[ :SENSE ] :PIManalyzer:FREQuency:STEP?
```

Title: PIM Master Frequency Sweep Step Size

Description: Sets Frequency Step Size for Swept PIM and Spectrum View measurement modes. The instrument may take up to 5 seconds to update this parameter and all dependent configurations.

Parameter: Frequency in Hz

Ranges: 100 kHz to 1000 kHz in 100 kHz increments

Example: To set the step size to 100 kHz:

```
:SENSE:PIManalyzer:FREQuency:STEP 100000
```

To get the frequency step size:

```
PIM:FREQ:STEP?
```

Front Panel

Access: **Freq**, Step Size

[:SENSe] :PIManalyzer:HIReflection:BYPass
[:SENSe] :PIManalyzer:HIReflection:BYPass?

Title: High Reflection Error Bypass

Description: Enables or disables the high reflection error bypass.

Parameter: OFF|ON|0|1

Parameter Type: <boolean>

Default Value: None. If no value is sent, then no action occurs. To verify that a value has been received, follow the command with a query.

Example: To enable the high reflection error bypass:

```
SENSe:PIManalyzer:HIReflection:BYPass ON
```

To query the state of the high reflection bypass:

```
PIM:HIR:BYPass?
```

Front Panel

Access: **Setup**, High Reflection Bypass

[:SENSe] :PIManalyzer:IMD:ORDER
[:SENSe] :PIManalyzer:IMD:ORDER?

Title: Measurement Receiver / PIM Master Intermodulation Distortion (IMD) Order Setup

Description: Sets the measurement receiver center frequency to receive one of the following IMDs from the PIM Master measurement system: 3/5/7. The query command returns the possible strings “3rd”, “5th”, and “7th” depending on the current selection of IMD Order.

Default Value: 3

Range: 3, 5, and 7 are the only acceptable values.

Example: To set the measurement receiver for the 5th order IMD:

```
:SENSe:PIManalyzer:IMD:ORDER 5
```

Sets the measurement receiver center frequency to the 5th order IMD.

Front Panel

Access: **Freq**, Intermod Order

[:SENSe] :PIManalyzer:IMFReq:BAND LOW | HIGH

[:SENSe] :PIManalyzer:IMFReq:BAND?

Title: Optional High/Low IMD frequency band selection

Description: Sets the receive IMD measurement frequency band only for the LTE-based 700 MHz options. This command works for all options that have band switching functionality, such as Option 210, Option 702, and Option 194. The command and the query are ignored by MW82119B PIM Masters with other instrument options.

Parameter: LOW | HIGH

Default Value: None. If no value is sent, then no action occurs. To verify that a value has been received, follow the command with a query.

Example: To set the measurement receiver to High Band:

```
:SENSe:PIManalyzer:IMFReq:BAND HIGH
```

Front Panel

Access: PIM vs. Time and Swept PIM:

Freq, High/Low Band Select

Distance-to-PIM:

Distance, High/Low Band Select

[:SENSe] :PIManalyzer:MEASure:STATus?

Title: PIM Analyzer Current Measurement Status

Description: The query returns the current measurement status of the measurement receiver/PIM Analyzer measurement system. Because the measurement system can run for the maximum time duration, the query serves to indicate if the measurement is still in process. This command works with any of the available measurement modes: PIM vs. Time, DTP, and Swept PIM.

Range: 0, Measurement is OFF
1, Measurement is ON

[:SENSe] :PIManalyzer:MEASure:VALue?

Title: Measurement Receiver Measured Value From PIM Master Measurement Setup

Description: This query returns the peak measured value in both dBc and dBm. For example, if the output power is set to 43 dBm and a PIM value of -80 dBm was read, then this command would return: -123.0, -80.0

This command is not supported for the Distance-To-PIM measurement mode. The dBc value should be ignored for the Noise Floor measurement modes.

A return value of -160 dBm for this query indicates that the measurement is invalid.

Query Response: <amplitude>, <amplitude>

Default Unit: dBc/dBm

Front Panel

Access: N/A. Intermodulation distortion value is displayed in the lower measurement box as "PIM".

**[:SENSe] :PIManalyzer:MODE PIM | PIMSwp | DTP | SPECTRUM_VIEW
 [:SENSe] :PIManalyzer:MODE?**

Title: PIM Analyzer Mode, Set or Request

Description: Puts the system into PIM vs. Time (PIM), Swept PIM (PIMSwp), Distance-to-PIM (DTP), or Spectrum View (SPECTRUM_VIEW) measurement mode. The query reports the current system mode. Changing to Swept PIM mode can take as long as 20 seconds.

Parameter: PIM | PIMSwp | DTP | SPECTRUM_VIEW

Query Response: PIM (PIM vs. Time)
 PIMSwp (Swept PIM)
 DTP (Distance-to-PIM)
 SPECTRUM_VIEW (Spectrum View)

Default Value: None. If no value is sent, then no action occurs. To verify that a value has been received, follow the command with a query.

Example: To set the PIM Analyzer mode to measure Distance-to-PIM:

```
:SENSe:PIManalyzer:MODE DTP
```

To query the state of the PIM Analyzer system:

```
:SENS:PIM:MOD?
```

Front Panel

Access: **Measurements**, PIM|Distance-to-PIM|Swept PIM|Noise Floor Measurements| Spectrum View

[:SENSe] :PIMAnalyzeR:OUTPut:POWer

[:SENSe] :PIMAnalyzeR:OUTPut:POWer?

Title: PIM Analyzer Output Power

Description: Sets the deliverable output (in dBm) from the PIM Analyzer to the system under test.

Parameter: dBm input with 0.1 dBm resolution

Default Value: None. If no value is sent, then no action occurs. To verify that a value has been received, follow the command with a query.

Range: 20 dBm to 46 dBm

Example: To set the PIM Analyzer output power to 43.5 dBm:

```
:SENSe:PIMAnalyzeR:OUTPut:POWer 43.5
```

Front Panel

Access: PIM vs. Time and Swept PIM: **Setup**, PIM Aid, Output Power

PIM vs. Time and Swept PIM: **Freq**, PIM Aid, Output Power

DTP: **Distance**, DTP Aid, Output Power

DTP: **Setup**, DTP Aid, Output Power

[:SENSe] :PIMAnalyzeR:RF:OUTput ON | OFF

[:SENSe] :PIMAnalyzeR:RF:OUTput?

Title: PIM vs. Time – Set RF Out On/Off

Description: This controls whether the RF is ON during a measurement, which corresponds to Normal and Noise Floor PVT measurements.

Parameter: ON | OFF

Default Value: ON | OFF

Range: 20 dBm to 46 dBm

Example: To turn on RF:

```
[ :SENSe ] :PIMAnalyzeR:OUTPut:POWer 43.5
```

Front Panel

Access: **Measurements**, PIM vs. Time, Test

[:SENSE] : PIManalyzer : SPECTrum : CURRent : MEASure : VALue?

Title: Measured Noise Floor Value from PIM Master

Description: The query returns the latest measured value of Spectrum View in dBm.

Related Command: [:SENSE] : PIManalyzer : SPECTrum : CURRent : FREQUency?

[:SENSE] : PIManalyzer : SPECTrum : MAX : MEASure : VALue?

Front Panel

Access: **N/A**. Signal value is displayed in the lower measurement box as “Signal Amplitude”.

[:SENSE] : PIManalyzer : SPECTrum : CURRent : FREQUency?

Title: Measured Noise Floor Frequency from PIM Master

Description: The query returns the latest measured frequency of Spectrum View in Hz.

Related Command: [:SENSE] : PIManalyzer : SPECTrum : CURRent : MEASure : VALue?

[:SENSE] : PIManalyzer : SPECTrum : MAX : FREQUency?

Front Panel

Access: **N/A**. Signal frequency is displayed in the lower measurement box after the “Signal Amplitude” in dBm.

[:SENSE] : PIManalyzer : SPECTrum : MAX : MEASure : VALue?

Title: Maximum Measured Noise Floor Value from PIM Master

Description: The query returns the maximum measured value of Spectrum View in dBm.

Related Command: [:SENSE] : PIManalyzer : SPECTrum : MAX : FREQUency?

[:SENSE] : PIManalyzer : SPECTrum : CURRent : MEASure : VALue?

Front Panel

Access: **N/A**. Maximum signal value is displayed in the lower measurement box as “Max Amplitude”.

[:SENSe] :PIManalyzer:SPECTrum:MAX:FREQuency?

Title: Frequency at Maximum Measured Noise Floor Value from PIM Master

Description: The query returns the frequency of the maximum signal measured in Spectrum View in Hz.

Related Command: [:SENSe] :PIManalyzer:SPECTrum:MAX:MEASure:VALue?

[:SENSe] :PIManalyzer:SPECTrum:CURREnt:FREQuency?

Front Panel

Access: **N/A**. Maximum signal frequency is displayed in the lower measurement box after the Max Amplitude dBm value.

[:SENSe] :PIManalyzer:SWEEp:FREQuency:F1 | 2?

Title: PIM Master Swept PIM F2 Stop Frequency Setup

Description: Queries the Swept PIM Fixed F1 or F2 frequency.

Parameter: Frequency in Hz

Default Unit: Hz

Range: PIM Master option dependent (for a list of ranges, refer to [Table B-1, "PIM Master Carrier Bands and Frequencies" on page B-2](#)).

Example: To get the Swept PIM Fixed F2 frequency:

```
PIM:SWEE:FREQ:F2?
```

Front Panel

Access: **NA** Note that fixed F1 and F2 frequencies are displayed in the lower measurement box in Swept Pim mode.

[:SENSe] :PIMAnalyzer :SWEEp :FREQuency :F1 :START
[:SENSe] :PIMAnalyzer :SWEEp :FREQuency :F1 :START?

Title: PIM Master Swept PIM F1 Start Frequency Setup

Description: Sets the Swept PIM F1 start frequency for the Fixed F2 sweep, then calculates the IMx sweep frequencies, and sets the instrument to display the corresponding IMx sweep frequencies.

Parameter: Frequency in Hz

Default Unit: Hz

Range: PIM Master option dependent (for a list of ranges, refer to [Table B-1, “PIM Master Carrier Bands and Frequencies”](#) on page B-2).

Example: To set the F1 start frequency to 1990 MHz:

```
:SENSe:PIMAnalyzer:SWEEp:FREQuency:F1:START 1990000000
```

To get the Swept PIM F1 start frequency:

```
PIM:SWEE:FREQ:F1:STAR?
```

Front Panel

Access: **Freq**, Swept PIM Aid, F1 Start

[:SENSe] :PIMAnalyzer :SWEEp :FREQuency :F1 :STOP
[:SENSe] :PIMAnalyzer :SWEEp :FREQuency :F1 :STOP?

Title: PIM Master Swept PIM F1 Stop Frequency Setup

Description: Sets the Swept PIM F1 stop frequency for the Fixed F2 sweep, then calculates the IMx sweep frequencies, and sets the instrument to display the corresponding IMx sweep frequencies.

Parameter: Frequency in Hz

Default Unit: Hz

Range: PIM Master option dependent (for a list of ranges, refer to [Table B-1, “PIM Master Carrier Bands and Frequencies”](#) on page B-2).

Example: To set the F1 stop frequency to 2110 MHz:

```
:SENSe:PIMAnalyzer:SWEEp:FREQuency:F1:STOP 2110000000
```

To get the Swept PIM F1 stop frequency:

```
PIM:SWEE:FREQ:F1:STOP?
```

Front Panel

Access: **Freq**, Swept PIM Aid, F1 Stop

[:SENSE] :PIMAnalyzer :SWEEP :FREQUENCY :F2 :START
[:SENSE] :PIMAnalyzer :SWEEP :FREQUENCY :F2 :START ?

Title: PIM Master Swept PIM F2 Start Frequency Setup

Description: Sets the Swept PIM F2 start frequency for the Fixed F1 sweep, then calculates the IMx sweep frequencies, and sets the instrument to display the corresponding IMx sweep frequencies.

Parameter: Frequency in Hz

Default Unit: Hz

Range: PIM Master option dependent (for a list of ranges, refer to [Table B-1, “PIM Master Carrier Bands and Frequencies”](#) on page B-2).

Example: To set the F2 start frequency to 758 MHz:

```
:SENSE:PIMAnalyzer:SWEEP:FREQUENCY:F2:START 758000000
```

To get the Swept PIM F2 start frequency:

```
PIM:SWEEP:FREQ:F2:STAR?
```

Front Panel

Access: **Freq**, Swept PIM Aid, F2 Start

[:SENSE] :PIMAnalyzer :SWEEP :FREQUENCY :F2 :STOP
[:SENSE] :PIMAnalyzer :SWEEP :FREQUENCY :F2 :STOP ?

Title: PIM Master Swept PIM F2 Stop Frequency Setup

Description: Sets the Swept PIM F2 stop frequency for the Fixed F1 sweep, then calculates the IMx sweep frequencies, and sets the instrument to display the corresponding IMx sweep frequencies.

Parameter: Frequency in Hz

Default Unit: Hz

Range: PIM Master option dependent (for a list of ranges, refer to [Table B-1, “PIM Master Carrier Bands and Frequencies”](#) on page B-2).

Example: To set the F2 stop frequency to 768 MHz:

```
:SENSE:PIMAnalyzer:SWEEP:FREQUENCY:F2:STOP 768000000
```

To get the Swept PIM F2 stop frequency:

```
PIM:SWEEP:FREQ:F2:STOP?
```

Front Panel

Access: **Freq**, Swept PIM Aid, F2 Stop

[:SENSE] :PIMAnalyzer:SWEEP:IMD:ORDER

[:SENSE] :PIMAnalyzer:SWEEP:IMD:ORDER?

Title: PIM Analyzer Swept PIM Intermodulation Distortion (IMD) Order Setup

Description: Sets the measurement receiver center frequency to receive one of the following IMDs from the PIM Analyzer measurement system: 3/5/7. The query command returns the possible strings “3rd”, “5th”, and “7th”, depending on the current selection of IMD Order.

Default Value: 3

Range: 3, 5, and 7 are the only acceptable values.

Example: To set the measurement receiver center frequency to the 5th order IMD:

```
:SENSE:PIMAnalyzer:SWEEP:IMD:ORDER 5
```

Front Panel

Access: **Freq**, Intermod Order

[:SENSE] :PIMAnalyzer:TEST:DURATION

[:SENSE] :PIMAnalyzer:TEST:DURATION?

Title: PIM Test Measurement Test Duration

Description: Sets the amount of time in seconds the PIM Master will be on for intermodulation distortion measurements.

Parameter: <time>

Default Value: 20

Default Unit: Seconds

Range: 1.0 to 1200.0 seconds

Example: To set the test duration time to 5 seconds:

```
:SENSE:PIMAnalyzer:TEST:DURATION 5.0
```

Front Panel

Access: **Setup**, Test Duration

4-8 :TRACe Subsystem

This subsystem contains commands related to the transfer of trace data to and from the instrument.

:TRACe [:DATA] ? <X>

Title: Trace Data Transfer

Description: This command transfers trace data from the instrument to the controller. Before executing this command, the instrument must be set to the desired measurement type.

In PIM vs. Time, Noise Floor – Time View, Noise Floor – Spectrum View, and Swept PIM measurement modes, a data point value of –160 dBm indicates an invalid value. In Distance-to-PIM mode, trace 1 and 2, a data point value of –200 dBm indicates an invalid value, and trace 3, a data point value of 100 dB indicates an invalid value.

The parameter **X** has a different meaning for each measurement mode. For PIM vs. Time, Noise Floor – Time View, and Noise Floor – Spectrum View, **X** should be **NULL** to retrieve trace data. For Distance-to-PIM, **X** must be **1** for the active trace, **2** for the DTP overlay trace, or **3** for the DTF overlay trace. For Swept PIM, **X** must be **1** for the Fixed F1 trace data, or **2** for the Fixed F2 trace data.

This command always returns data values in dBm for all measurement traces except trace 3 for Distance-to-PIM mode, which returns dB units.

Parameter: NULL | 1 | 2 | 3

Parameter Type: <char>

Example: To query the data points of a PIM vs. Time trace:

```
:TRAC:DATA?
```

```
:TRAC?
```

To query the data points of a Swept PIM Fixed F1 trace:

```
:TRAC:DATA? 1
```

```
:TRAC? 1
```

To query the data points of a Distance-To-PIM DTF Overlay trace:

```
:TRAC:DATA? 3
```

```
:TRAC? 3
```

Front Panel

Access: **NA**

Chapter 5 — Cable & Antenna Commands

5-1 :CALCulate Subsystem

The commands in this subsystem process data that has been collected via the SENSE subsystem.

:CALCulate:LIMit:ALARm OFF | ON | 0 | 1

:CALCulate:LIMit:ALARm?

Title: Limit Alarm

Description: Enables/disables the currently active limit line alarm. Setting the value to ON or 1 will turn on the limit alarm. Setting the value to OFF or 0 will turn off the limit alarm. The query version of the command returns a 1 if the currently selected limit line alarm is set to ON and returns 0 if OFF.

Parameter: OFF | ON | 0 | 1

Parameter Type: <boolean>

Default Value: OFF

Example: To turn off limit alarm:

```
:CALCulate:LIMit:ALARm OFF
:CALCulate:LIMit:ALARm 0
```

To turn on limit alarm:

```
:CALCulate:LIMit:ALARm ON
:CALCulate:LIMit:ALARm 1
```

Front Panel

Access: Shift-6 (Limit), Limit Alarm

:CALCulate:LIMit:CLEAr

Title: Clear Selected Limit

Description: Deletes all limit points for the currently active limit line.

Front Panel

Access: Shift-6 (Limit), Clear Limit

:CALCulate:LIMit:POINT:ADD

Title: Add Limit Point

Description: Adds a new limit point to the currently active limit line.

Front Panel

Access: Shift-6 (Limit), Multi-Segment Edit, Add Point

:CALCulate:LIMit:POINT:FREQUency <freq>

:CALCulate:LIMit:POINT:FREQUency?

Title: Limit Point Frequency

Description: Sets the limit point frequency of the current selected limit.

Parameter: <freq>

Default Unit: Hz

Front Panel

Access: Shift-6 (Limit), Multi-Segment Edit, Point Freq

:CALCulate:LIMit:POINT:VALue <value>

:CALCulate:LIMit:POINT:VALue?

Title: Limit Point Value

Description: Sets the limit point value of the current selected limit. The <value> parameter is the limit point value in dB or time units for group delay.

Parameter: <value>

Default Unit: Current active value unit.

Front Panel

Access: Shift-6 (Limit), Multi-Segment Edit, Point Value

:CALCulate:LIMit:POINT?

Title: Number of Limit Points

Description: Returns the number of points currently in the selected limit line.

:CALCulate:LIMit[:STATE] OFF|ON|0|1
:CALCulate:LIMit[:STATE]?

Title: Limit State

Description: Turns the limit line ON or OFF. If the value is set to ON or 1, the currently selected limit line is ON. If the value is set to OFF or 0, the currently selected limit line is OFF. The query version of the command returns a 1 if the currently selected limit line is ON and returns a 0 if OFF.

Parameter: OFF|ON|0|1

Parameter Type: <boolean>

Default Value: OFF

Example: To turn on the limit line:

```
:CALCulate:LIMit ON
:CALCulate:LIMit:STATE ON
:CALCulate:LIMit:STATE 1
```

To turn off the limit line:

```
:CALCulate:LIMit OFF
:CALCulate:LIMit:STATE 0
:CALCulate:LIMit 0
```

Front Panel

Access: Shift-6 (Limit), Limit On/Off

:CALCulate:MARKer:AOff

Title: Turn All Markers Off

Description: Turns off all markers.

Front Panel

Access: Marker, All Markers Off

:CALCulate:MARKer:TABLE:DATA?

Title: Marker Table Data

Description: Reports marker information similar to the Marker table. The response begins with an ASCII header. The header specifies the number of following bytes. It looks like #AX, where A is the number of digits in X and X is the number of bytes that follow the header. Parameters are returned in comma-delimited ASCII format. Each parameter is returned as "NAME=VALUE[UNITS]."

Parameter Name	Description
MKR_REFx	Reference marker state
MKR_DLTx	Delta marker state.
MKR_REF_FREQNx	Reference marker x frequency
MKR_DLT_FREQNx	Delta marker x frequency
MKR_REF_AMPLy	Reference marker y-axis
MKR_DLT_AMPL	Delta marker y magnitude.

x = marker 1 to 6.

Front Panel

Access: Marker, Marker Table On

:CALCulate:MARKer:TABLE[:STATE] OFF|ON|0|1**:CALCulate:MARKer:TABLE[:STATE]?**

Title: Marker Table State

Description: Turns the Marker Table on or off. Setting the value to ON or 1 will turn on the marker table. Setting the value to OFF or 0 will turn off the marker table.

Parameter: OFF|ON|0|1

Parameter Type: <boolean>

Default Value: OFF

Example: To turn on marker table:

```
:CALCulate:MARKer:TABLE ON
:CALCulate:MARKer:TABLE 1
```

Front Panel

Access: Marker, Marker Table

:CALCulate:MARKer{1|2|3|4|5|6}:DELTA:X <x-parameter>
:CALCulate:MARKer{1|2|3|4|5|6}:DELTA:X?

Title: Delta Marker X Value

Description: Sets the location of the delta marker on the x-axis at the specified location <x-parameter> + the reference marker x-axis. <x-parameter> is defined in the current x-axis units. The query version of the command returns the location of the delta marker on the x-axis.

Parameter: <x-parameter>

Default Unit: Current x-axis unit

Example: If both the reference and delta marker #1 is currently at 1 GHz on the x-axis, send the command below to set the delta marker #1 to 2 GHz on the x-axis:

```
:CALCulate:MARKer1:DELTA:X 1GHz
```

Related Command: :CALCulate:MARKer[1|2|3|4|5|6]:X

Front Panel

Access: Marker, Delta

:CALCulate:MARKer{1|2|3|4|5|6}:DELTA:Y?

Title: Delta Marker Read Y Value

Description: Reads the current Y value for the specified delta marker. The units are the units of the y-axis.

Default Unit: Current y-axis unit

:CALCulate:MARKer{1|2|3|4|5|6}:DELTA[:STATE] OFF|ON|0|1
:CALCulate:MARKer{1|2|3|4|5|6}:DELTA[:STATE]?

Title: Delta Marker State

Description: Sets the specified delta marker on or off.

Parameter: OFF|ON|0|1

Parameter Type: <boolean>

Default Value: OFF

Example: To turn on delta marker #3:

```
:CAL1Culate:MARKer3:DELTA ON
:CALCulate:MARKer3:DELTA 1
:CALCulate:MARKer3:DELTA:STATE ON
:CALCulate:MARKer3:DELTA:STATE 1
```

To turn off delta marker #6

```
:CALCulate:MARKer6:DELTA OFF
:CALCulate:MARKer6:DELTA:STATE OFF
:CALCulate:MARKer6:DELTA:STATE 0
```

Front Panel

Access: Marker, Delta

:CALCulate:MARKer{1|2|3|4|5|6}:PEAK

Title: Marker Peak Search

Description: Puts the specified marker at the maximum value in the trace.

Front Panel

Access: Marker, Marker [1/2/3/4/5/6], Marker to Peak

:CALCulate:MARKer{1|2|3|4|5|6}:VALley

Title: Marker Valley Search

Description: Puts the specified marker at the minimum value in the trace.

Front Panel

Access: Marker, Marker [1/2/3/4/5/6], Marker to Valley

:CALCulate:MARKer{1|2|3|4|5|6}:X <x-parameter>**:CALCulate:MARKer{1|2|3|4|5|6}:X?**

Title: Marker X Value

Description: Sets the location of the marker on the x-axis at the specified location. <x-parameter> is defined in the current x-axis units. The query version of the command returns the location of the marker on the x-axis. Note that the marker is snapped to the data point closest to the specified value. If the specified marker is not on, it is set to on.

Parameter: <x-parameter>

Default Unit: Current x-axis unit

Example: To set reference marker #2 to 1GHz on the x-axis:

```
:CALCulate:MARKer2:X 1GHz
```

To set reference marker #1 to 1.5 GHz on the x-axis:

```
:CALCulate:MARKer:X 1.5GHz
```

```
:CALCulate:MARKer1:X 1.5GHz
```

Front Panel

Access: Marker, Marker [1/2/3/4/5/6]

:CALCulate:MARKer{1|2|3|4|5|6}:Y?

Title: Marker Read Y Value

Description: Reads the current Y value for the specified marker. The units are the units of the y-axis.

Default Unit: Current y-axis unit

```
:CALCulate:MARKer{1|2|3|4|5|6}[:STATe] OFF|ON|0|1
:CALCulate:MARKer{1|2|3|4|5|6}[:STATe]?
```

Title: Marker State

Description: Sets the specified marker on/off. If no marker is specified in {1|2|3|4|5|6}, then marker defaults to 1.

Parameter: OFF|ON|0|1

Parameter Type: <boolean>

Default Value: OFF

Example: To turn off reference marker #1:

```
:CALCulate:MARKer1:STATe OFF
```

Front Panel

Access: Marker, On/Off

```
:CALCulate:MATH:FUNCTION NORMAl|ADD|SUBTract
:CALCulate:MATH:FUNCTION?
```

Title: Trace Math Function

Description: Sets math operations on the currently selected measurement and the trace stored in memory. Note that there MUST be a trace stored in Memory. Setting the FUNCTION to NORMAl is equivalent of setting the Trace Math to “No Trace Math” on the front panel. Setting the FUNCTION to ADD is equivalent of setting the Trace Math to “Trace Plus Memory” on the front panel. Setting the FUNCTION to SUBTract is equivalent to setting the Trace Math to “Trace Minus Memory” on the front panel. The query version of the command returns the string “NORM” for no trace math, returns the string “ADD” for trace plus memory, and returns the string “SUBT” for trace minus memory.

Parameter: NORMAl|ADD|SUBTract

Parameter Type: <char>

Default Value: NORMAl

Range: NORMAl|ADD|SUBTract

Related Command: :CALCulate:MATH:MEMorize

Front Panel

Access: Shift-5 (Trace)

```
:CALCulate:MATH:MEMorize
```

Title: Trace To Memory

Description: Copies the current measurement trace into memory.

Front Panel

Access: Shift-5 (Trace), Copy Trace To Display Memory

:CALCulate:MATH:OVERlay ON|OFF

Title: Trace Overlay On/Off

Description: Turns trace stored in memory on or off.

Front Panel

Access: Shift-5 (Trace), Trace Overlay

:CALCulate:SMOothing <integer>**:CALCulate:SMOothing?**

Title: Smoothing

Description: Sets the smoothing percentage. The query form of the command returns the current smoothing percentage.

Parameter: <integer>

Parameter Type: <integer>

Default Value: 0

Default Unit: %

Range: 0 to 10

Front Panel

Access: Shift-3 (Sweep), Averaging Smoothing, Smoothing %

:CALCulate:TRANSform:CLAverage?

Title: Cable Loss Average

Description: Reports the cable loss average.

Default Value: 0 dB

Default Unit: dB

:CALCulate:TRANSform:DISTance:CABLoss**:CALCulate:TRANSform:DISTance:CABLoss?**

Title: Cable Loss

Description: Sets the cable loss for DTF measurements.

Default Value: 0

Range: 0.0 to 5

Front Panel

Access: Measurements, Cable Loss

:CALCulate:TRANSform:DISTance:DMAX?

Title: Distance Maximum

Description: Reports the maximum horizontal distance that can be analyzed in DTF. Note that the unit return is based on the current distance units.

Default Value: Dependent on instrument model number and frequency range.

Default Unit: Meters (m)

Range: 0.0 m to 1500 m

:CALCulate:TRANSform:DISTance:FRESolution?

Title: Fault Resolution

Description: Reports the system's ability to separate two closely spaced discontinuities in DTF measurements. Note that the return value is based on the current distance units.

Default Value: Dependent on instrument model number and frequency range.

Default Unit: Meters (m)

Range: 0.0 m to 1500 m

:CALCulate:TRANSform:DISTance:PVELocity**:CALCulate:TRANSform:DISTance:PVELocity?**

Title: Propagation Velocity

Description: Sets the propagation velocity of the cable for DTF measurements.

Default Value: 0.8

Range: 0.001 to 1.0

Front Panel

Access: Freq/Dist, More, Prop Velocity (Note: For DTF measurements only.)

:CALCulate:TRANSform:DISTance:START**:CALCulate:TRANSform:DISTance:START?**

Title: Start Distance

Description: Sets the start distance for DTF measurements.

Default Value: 0.0 m

Default Unit: Meters (m)

Range: 0.0 m to 1000.0 m

Front Panel

Access: Freq/Dist, Start Dist

:CALCulate:TRANSform:DIStance:STOP
:CALCulate:TRANSform:DIStance:STOP?

Title: Stop Distance

Description: Sets the stop distance for DTF measurements.

Default Unit: Meters (m)

Range: 0.0 m to 1000.0 m

Front Panel

Access: Freq/Dist, Stop Dist

:CALCulate:TRANSform:DIStance:UNIT METers | FEET
:CALCulate:TRANSform:DIStance:UNIT?

Title: Distance Units

Description: Sets the units to be used for DTF measurements.

Parameter: METers | FEET

Parameter Type: <char>

Default Value: Meters

Range: METers | FEET

Front Panel

Access: Freq/Dist, Units

:CALCulate:TRANSform:DIStance:WINDow
RECTangular | MSLobe | NSLobe | LSLobe
:CALCulate:TRANSform:DIStance:WINDow?

Title: Windowing

Description: Sets the windowing for DTF measurements. Available types are Rectangular, Nominal Side Lobe, Low Side Lobe and Minimum Side Lobe.

Parameter: RECTangular | MSLobe | NSLobe | LSLobe

Parameter Type: <char>

Default Value: Rectangular

Range: RECTangular | MSLobe | NSLobe | LSLobe

Front Panel

Access: Freq/Dist, More, Window

5-2 :CALibration Subsystem

This subsystem controls the system calibration.

:CALibration:STATE?

Title: Calibration State

Description: Reports the calibrated state. This command returns a 1 if the instrument has been calibrated with discrete Open, Short, and Load components and returns 0 if the instrument has not been calibrated.

Related Command: [:SENSe] CORRection:COLL:LOAD
[:SENSe] CORRection:COLL:OPEN
[:SENSe] CORRection:COLL:SHORT

5-3 :CONFigure Subsystem

This set of commands prepares the instrument for the selected measurement. It disables any currently-enabled measurements and activates the specified measurement. It sets the instrument to single sweep mode, waiting for an :INITiate command. It will not initiate the taking of a measurement.

Current instrument settings may be changed to default values. These changes are identified with their respective measurement commands.

Note In dual display mode, the top and bottom channels CANNOT be the same measurement type.

:CONFigure:MEASure?

Title: Current Active Measurement Mode

Description: Reports the current active measurement mode.

Front Panel

Access: Measurements (Active measurement is indicated by the red radial button.)

:CONFigure:MEASure:ACTiveChan 0 | 1

:CONFigure:MEASure:ACTiveChan?

Title: Active Channel 0/1

Description: Toggles between channel 0 (top) and 1 (bottom). Only functional in Dual Display Mode.

Front Panel

Access: Measurements (Active measurement is indicated by the red radial button.)

:CONFigure:MEASure:DUALdisplay DUAL | SINGLE

:CONFigure:MEASure:DUALdisplay?

Title: Dual Display On/Off

Description: Turns dual display on or off.

Front Panel

Access: Measurements, Display Format

:CONFigure:MEASure:RLDTf

Title: Configure DTF Return Loss

Description: Changes the Cable & Antenna measurement to DTF Return Loss.

Front Panel

Access: Shift-4 (Measure), DTF Return Loss

:CONFigure:MEASure:RLFReq

Title: Configure Return Loss

Description: Changes the current measurement to Return Loss.

Front Panel

Access: Shift-4 (Measure), Return Loss

:CONFigure:MEASure:1PHase

Title: Configure 1-Port Phase Measurement

Description: Changes the current measurement to 1-Port Phase.

Front Panel

Access: Shift-4 (Measure), More, 1-Port Phase

:CONFigure:MEASure:SMCHart

Title: Configure Smith Chart

Description: Changes the measurement to Smith Chart.

Front Panel

Access: Shift-4 (Measure), More, Smith Chart

:CONFigure:MEASure:SWRDtf

Title: Configure DTF VSWR

Description: Changes the measurement to DTF VSWR.

Front Panel

Access: Shift-4 (Measure), DTF VSWR

5-4 :DISPlay Subsystem

This subsystem provides commands that modify the display of data for the user. They do not modify the way in which data are returned to the controller.

:DISPlay:WINDow:TRACe:Y[:SCALE]:AUToscale

Title: Autoscale

Description: Autoscales the active channel display so that the trace is shown in the middle of the display.

Front Panel

Access: Amplitude, Autoscale

:DISPlay:WINDow:TRACe:Y[:SCALE]:BOTTom <value>

Title: Scale Bottom level.

Description: Sets the Bottom value for the current graph. This command is invalid for Smith charts.

Default Unit: Current active amplitude unit

Range: Log Magnitude: 0 dB to 60 dB
Phase: -180 degree to 90 degree
VSWR: 1 to 65
DTF RL: 0 dB to 60 dB
DTF VSWR: 1 to 65

Front Panel

Access: Amplitude, Bottom

:DISPlay:WINDow:TRACe:Y[:SCALE]:TOP <value>

Title: Scale Top level.

Description: Sets the Top value for the current graph. This command is invalid for Smith charts.

Default Unit: Current active amplitude unit

Range: Log Magnitude: 0 dB to 60 dB
Phase: -180 degree to 90 degree
VSWR: 1 to 65
DTF RL: 0 dB to 60 dB
DTF VSWR: 1 to 65

Front Panel

Access: Amplitude, Top

```
:DISPlay:WINDow:TRACe:Y[:SCALe]:SMCHart 0|10|20|30|-3  
:DISPlay:WINDow:TRACe:Y[:SCALe]:SMCHart?
```

Title: Smith Chart Scalable Type

Description: Sets the Smith chart display scale type. Setting the value to 0 is equivalent of setting the Smith Chart scale to “Normal” on the front panel. Setting the value to 10 is equivalent of setting the Smith Chart scale to “Expand 10dB” on the front panel. Setting the value to 20 is equivalent of setting the Smith Chart scale to “Expand 20dB” on the front panel. Setting the value to 30 is equivalent of setting the Smith Chart scale to “Expand 30dB” on the front panel. Setting the value to -3 is equivalent of setting the Smith Chart scale to “Compress 3dB” on the front panel.

Parameter: 0|10|20|30|-3

Default Value: Normal

Default Unit: Current active amplitude unit

Range: 0|10|20|30|-3

Front Panel

Access: Amplitude (In Smith Chart measurement view.)

5-5 :FORMat Subsystem

This subsystem contains commands that determine the formatting of numeric data when it is transferred.

The format setting affects data in specific commands only. If a command is affected, then it is noted in the command description.

:FORMat [:READings] [:DATA] ASCii | INTeger,32 | REAL,32

:FORMat [:READings] [:DATA] ?

Title: Numeric Data Format

Description: This command specifies the format in which data is returned in certain commands.

ASCii format returns the data in comma-separated ASCII format. The units are the current instrument units. This format requires many more bytes so it is the slowest format. INTeger,32 values are signed 32-bit integers in little-endian byte order. This format returns the data in 4-byte blocks.

The units are always mdBm. For example, if the measured result were -12.345 dBm, that value would be sent as -12345.) REAL,32 values are 32-bit floating point numbers conforming to the IEEE 754 standard in little-endian byte order. This format returns the data in 4-byte binary format. The units are the current instrument units.

Both INTeger,32 and REAL,32 formats return a definite block length. Each transfer begins with an ASCII header such as #42204. The first digit represents the number of following digits in the header (in this example, 4). The remainder of the header indicates the number of bytes that follow the header (in this example, 2204). You then divide the number of following bytes by the number of bytes in the data format you've chosen (4 for both INTeger,32 and REAL,32) to get the number of data points (in this example, 551).

Parameter: ASCii | INTeger,32 | REAL,32

Parameter Type: <char>

Default Value: ASCii

Related Command: :TRACe [:DATA]

Interpreting Returned Data Pair

The following section provides two conversion examples on interpreting returned data pairs. Examples are provided for both integer and real number formats.

Converting INTeger,32 and REAL,32 Values

- For a 551 point trace, the instrument returns 4415 bytes.
 - The first 7 bytes make up the “header” information in ASCII format.
 - The next 4408 bytes make up the actual data (8 bytes x 551 datapoints = 4408 total bytes).
- Each datapoint consists of 8 bytes.
 - The first 4 bytes are the real component
 - The next 4 bytes are the imaginary component.
- The returned value is in little endian format (the little end comes first).
- Negative numbers are represented in two’s compliment format.
- The data is scaled by a factor of 1e6.

Converting INTeger,32 Example:

The instrument returns the following S_{11} RL data point in INT,32 format:

4d 15 fc ff [real], ef a2 f8 ff [imag]

1. Convert from little endian to big endian:

ff fc 15 4d [real], ff f8 a2 ef [imag]

2. Since the MSb in both components is 1, they are negative numbers.

3. The binary representation is:

11111111111111000001010101001101 [real], 11111111111110001010001011101111 [imag]

4. Convert from two’s complement (not the bits and add 1):

111110101010110011 [real], 1110101110100010001 [imag]

5. Convert the binary values to decimal:

256691 [real], 482577 [imag]

6. Take out the 1e6 scale factor:

0.256691 [real], 0.482577 [imag]

7. Finally, convert the values to dB:

$10 \cdot \log(0.256691^2 + 0.482577^2) = -5.25 \text{ dB}$

Converting REAL,32 Example:

The instrument returns the following values in REAL,32 format:

00 31 2a 47 [real], 00 e8 6a c6 [imag]

1. Convert from little endian to big endian:

47 2a 31 00 [real], c6 6a e8 00 [imag]

2. The binary representation of the real portion, 47 2a 31 00 is:

01000111 00101010 01110001 00000000

3. Binary is in IEEE format:

- 1st bit is sign bit
- next 8 bits are exponent
- next 23 bits are normalized value

4. Convert binary to decimal:

0, the MSb is the sign bit

10001110, exponent. The actual exponent value is this value minus 127. So, it is $142 - 127 = 15$.

0101010 01110001 00000000 (as normalized value) and adding 1 and multiplying by 2^{exponent} results in $1 + (0/2 + 1/4 + 0/8 + 1/16 + 0/32 + 1/64 + \dots) * 2^{15} = 43520$ (approx.)

5. Repeat [Step 2](#) through [Step 4](#) for the imaginary portion.

c6 6a e8 00 in binary is 11000110 01101010 11101000 00000000

The MSb is the sign bit

The next 8 bits are the exponent, which is 10001100. The actual value is $140 - 127 = 13$

Converting the remaining bits and multiplying by exponent and accounting for sign, results in $-(1 + (1/2 + 1/4 + 0/8 + 1/16 + 0/32 + 1/64 + \dots) * 2^{13}) = -14976$ (approx).

6. Take out the $1e6$ scale factor from both parts:

.043520 [real], -.014976 [imag]

7. Finally, convert the values to dB:

$10 * \log((.043520)^2 + (-.014976)^2) = -26.7401848$ dB

5-6 :INITiate Subsystem

This subsystem controls the triggering of measurements.

:INITiate:CONTInuous OFF | ON | 0 | 1

:INITiate:CONTInuous?

Title: Continuous/Single Sweep

Description: Specifies whether the sweep/measurement is triggered continuously. If the value is set to ON or 1, then another sweep/measurement is triggered as soon as the current one completes. If continuous is set to OFF or 0, then the instrument enters the “idle” state and waits for the :INITiate[:IMMEDIATE] command or for :INITiate:CONTInuous ON. The default value is ON. That is, sending :INIT:CONT is equivalent to sending :INIT:CONT ON. The query version of the command returns a 1 if the instrument is continuously sweeping/measuring and returns a 0 if the instrument is in single sweep/measurement mode. Note that rapid toggling between ON and OFF is not allowed. The instrument must be allowed to make a full sweep before toggling can be done. Note that the set command is available only if the instrument is in Cable & Antenna mode.

Parameter: OFF | ON | 0 | 1

Parameter Type: <boolean>

Default Value: 1

Related Command: :INITiate[:IMMEDIATE]
:INITiate:HOLD

Front Panel

Access: Shift-3 (Sweep), Sweep Type

:INITiate:HOLD OFF | ON | 0 | 1

:INITiate:HOLD?

Title: Hold Sweep

Description: Stops a sweep at its current measurement point. If the instrument is currently sweeping, setting a value of ON or 1, will pause the sweep. If the instrument is currently not sweeping, setting a value of OFF or 0, will resume sweeping. The query version of the command returns a 1 if the hold command is set and returns a 0 if a Run is set instead. Note that the set command is available only if the instrument is in Cable & Antenna mode.

Parameter: OFF | ON | 0 | 1

Parameter Type: <boolean>

Default Value: 0

Front Panel

Access: Shift-3 (Sweep), Run/Hold

:INITiate[:IMMEDIATE]

Title: Trigger Sweep/Measurement

Description: Initiates a sweep/measurement. If :INITiate:CONTinuous is set to ON, this command is ignored. Use this command in combination with :STATus:OPERation? to synchronize the capture of one complete set of data. When this command is sent, the “sweep complete” bit of :STATus:OPERation? is set to 0, indicating that the measurement has not completed. The data collection is then triggered. The controlling program can poll :STATus:OPERation? to determine the status. When the “sweep complete” bit is set to 1, data is ready to be retrieved.

Related Command: :INITiate:CONTinuous
:STATus:OPERation?

Front Panel

Access: Shift-3 (Sweep), Run/Hold, Run

(Note: When the unit is in “Hold Mode”, sending this command will initiate a sweep from the point at which is left off.)

5-7 :MMEMory Subsystem

The Mass MEMory subsystem contains functions that provide access to the instrument's setup and data storage.

:MMEMory:DELeTe <file name>

Title: Delete Setup/Measurement

Description: Removes the measurement or setup file specified by <file name> from the current mass storage device. <file name> should be enclosed in either single quotes (') or double quotes ("). It should contain one of the following file extensions:

“.stp” for setup

“.dat” for C&AA measurements

“.pim” for PIM measurement

“.vna” for C&AA measurements

Use the command MMEMory:MSIS to set the current mass storage location.

Parameter: <file name>

Related Command: :MMEMory:STORE:STATe
:MMEMory:STORE:TRACe
:MMEMory:MSIS INTernal | USB

Front Panel

Access: Shift-7 (File), Delete, Delete Selected File

:MMEMory:LOAD:STATe <integer>,<file name>

Title: Recall Setup

Description: Recalls a previously stored instrument setup in the current storage location. The setup file to be loaded is specified by <file name>. <file name> should be enclosed in either single quotes (') or double quotes (") and should contain a file extension “.stp”. Use the command :MMEMory:MSIS to set the current storage location. The <integer> parameter is not currently used, but it must be sent. Send a 1.

Parameter: <integer>, <file name>

Related Command: :MMEMory:STORE:STATe
:MMEMory:MSIS INTernal | USB

Front Panel

Access: Shift-7 (File), Recall

:MMEMory:LOAD:TRACe <integer>,<file name>

Title: Recall Measurement

Description: The instrument must be in the mode of the saved trace in order to recall that trace. Use :INSTrument:SElect or :INSTrument:NSElect to set the mode.

Recalls a previously stored measurement trace from the current storage location. The saved measurement trace to be loaded is specified by <file name>. <file name> should be enclosed in either single quotes (') or double quotes (" ") and should contain a file extension. Note that the trace specified by <file name> should be available at the current mass storage location. Use the command MMEMory:MSIS to set the current mass storage location. The <integer> parameter is not currently used, but it must be sent. Send a 1.

File name extensions:

“.dat” for C&AA measurements

“.vna” for C&AA measurements

Parameter: <integer>, <file name>

Example: To recall trace with file name “trace”:

```
:MMEMory:LOAD:TRACe 1,"trace.spa"
```

Related Command: :MMEMory:STORe:TRACe
:MMEMory:STORe:TRACe
:MMEMory:MSIS INTernal|USB

Front Panel

Access: Shift-7 (File), Recall Measurement

:MMEMory:STORe:STATe <integer>,<file name>

Title: Save Setup

Description: Stores the current setup into the file specified by <file name>. <file name> should be enclosed in either single quotes (') or double quotes (" ") and should not contain a file extension. Use the command MMEMory:MSIS to set the current storage location. The <integer> parameter is not currently used, but it must be sent. Send a value of 0.

Parameter: <integer>, <file name>

Related Command: :MMEMory:LOAD:STATe
:MMEMory:MSIS INTernal|USB

Front Panel

Access: Shift-7 (File)

:MMEMory:STORe:TRACe <integer>,<file name>

Title: Save Measurement

Description: Stores the trace into the file specified by <file name>. <file name> should be enclosed in either single quotes (') or double quotes (") and should not contain a file extension. Use the command MMEMory:MSIS to set the current storage location. The <integer> parameter is not currently used, but it must be sent. Send a 0. This command saves .vna only. The .vna extension is automatically appended to the end of the filename entered in this command.

Parameter: <integer>, <file name>

Example: To save the trace into the file name "trace":

```
:MMEMory:STORe:TRACe 0,"trace"
```

Related Command: :MMEMory:LOAD:TRACe
:MMEMory:MSIS INTernal|USB

Front Panel

Access: Shift-7 (File), Save

5-8 :TRACe Subsystem

This subsystem contains commands related to the transfer of trace data to and from the instrument.

:TRACe:PREamble? [1]

Title: Trace Header Transfer

Description: Returns trace header information for the trace. Use the commands in the MMEMory subsystem to store and recall traces from the instrument memory. The response begins with an ASCII header. The header specifies the number of following bytes. It looks like #AX, where A is the number of digits in X and X is the number of bytes that follow the header. Parameters are returned in comma-delimited ASCII format. Each parameter is returned as "NAME=VALUE[UNITS]," Note that currently only Trace A header is retrieved. Valid parameters are shown in "[Parameter Names](#)" on page 2-11.

Parameter: [1]

Related Command: :TRACe:DATA

:TRACe[:DATA]? [1]

Title: Trace Data Query

Description: Transfers the current active trace data from the instrument to the controller. The format of the block data that is returned can be specified by the command :FORMat:DATA. The block data in the command form is always sent in ASCII format.

The response begins with an ASCII header that specifies the number of data bytes. It looks like #AX, where A is the number of digits in X and X is the number of bytes that follow the header. Each data point is separated by a comma delimiter. Except for the group delay, each data point consists of real and imaginary pair scaled by 10^6 . Thus for a 551 point trace there is a total of 1102 points.

Trace setup information can be acquired using :TRACe[:DATA]:PREamble?.

For sweep resolutions ≥ 551 , this command will return X data points. At 275 data points the values returned are paired and at 137 data points the values are in fours.

Parameter: [1]

Related Command: :FORMat[:READings][:DATA]
:TRACe[:DATA]:PREamble?

5-9 [:SENSE] Subsystem

The commands in this subsystem relate to device-specific parameters, not signal-oriented parameters.

[:SENSE]:AVERAGE:CLEAR

Title: Restart Averaging

Description: Clears and restarts averaging of the measurement data. Note that averaging state must be ON for averaging to restart.

Related Command: [:SENSE]:AVERAGE[:STATE]

Front Panel

Access: Shift-3 (Sweep), Averaging Smoothing, Restart

[:SENSE]:AVERAGE:COUNT <integer>

[:SENSE]:AVERAGE:COUNT?

Title: Number of Traces to Average

Description: Sets the number of traces to average.

Parameter: <integer>

Parameter Type: <integer>

Default Value: 10

Range: 2 to 65535

Front Panel

Access: Shift-3 (Sweep), Averaging Smoothing, Averaging Factor

[:SENSE]:AVERAGE[:STATE] OFF|ON|0|1

[:SENSE]:AVERAGE[:STATE]?

Title: Averaging State

Description: Turns trace averaging ON or OFF. Setting the value to ON or 1 will result in turning trace averaging ON.

Parameter: OFF|ON|0|1

Parameter Type: <boolean>

Default Value: OFF

Front Panel

Access: Shift-3 (Sweep), Averaging Smoothing, Averaging

[:SENSe]:CORRection:COLLect:ABORt

Title: Calibration Abort

Description: Aborts the calibration measurement and restarts the current sweep and/or measurement.

Related Command: [:SENSe]:CORRection:COLLect:INITialize
 [:SENSe]:CORRection:COLLect:OPEN
 [:SENSe]:CORRection:COLLect:SHOR
 [:SENSe]:CORRection:COLLect:LOAD

[:SENSe]:CORRection:COLLect:INITialize

Title: Calibration Initialize

Description: Shift-2 (Calibrate), Configure DUT User, Short Initiates the calibration process. This command must be issue before sending Open, Short, or Load commands. Use the query command [:SENSe]:CORRection:COLLect:STATUs? to check if initialization has completed and that the next calibrate step can be proceeded.

Notes:

1. Once the calibration sequence has been initialized remotely, calibration steps must be completed remotely. To exit the calibration sequence before it is completed use the ABORt command.
2. During calibration Data Points is set to 551. Set to desired Data Points value after calibration is completed.

Related Command: [:SENSe]:CORRection:COLLect:STATUs?
 [:SENSe]:CORRection:COLLect:OPEN
 [:SENSe]:CORRection:COLLect:SHORt
 [:SENSe]:CORRection:COLLect:LOAD
 [:SENSe]:CORRection:COLLect:ABORt

[:SENSe]:CORRection:COLLect:LOAD

Title: Calibration Load

Description: Starts the Load calibration measurement. This is the last calibration steps for 1-Port (OSL) and the third calibration steps for 2- Port (OSLT). Note that the Calibration Short process must be completed before calling this command. You must also connect the Load to the RF Out port (or to the end of the test port extension cable) prior to issuing this command. Use the query command [:SENSe]:CORRection:COLLect:STATUs? to check if the Load calibration measurement has completed and that the next calibrate step can be proceeded.

Related Command: [:SENSe]:CORRection:COLLect:STATUs?
 [:SENSe]:CORRection:COLLect:INITialize
 [:SENSe]:CORRection:COLLect:OPEN
 [:SENSe]:CORRection:COLLect:SHORt

[:SENSe]:CORRection:COLLect:OPEN

Title: Calibration Open

Description: Starts the Open calibration measurement. This is the first calibration step for both the 1-Port (Open-Short-Load) and 2-Port (Open-Short-Load) calibration. Note that the initialize step [:SENS]:CORR:COLL:INIT must be completed before calling this command. Note that you must connect the Open to the RF Out port (or to the end of the test port extension cable) before issuing this command. Use the query command [:SENSe]:CORRection:COLLect:STATus? to check if the Open calibration measurement has completed and that the next calibrate step can be proceeded.

Related Command: [:SENSe]:CORRection:COLLect:STATus?
[:SENSe]:CORRection:COLLect:INITialize,

[:SENSe]:CORRection:COLLect:SHORT

Title: Calibration Short

Description: Starts the Short calibration measurement. This is the second calibration step for both the 1-Port (Open-Short-Load) and 2-Port (Open-Short-Load) calibration. Note that the Calibration Open process must be completed before calling this command. You must also connect the Short to the RF Out port (or to the end of the test port extension cable) before issuing this command. Use the query command [:SENSe]:CORRection:COLLect:STATus? to check if the Short calibration measurement has completed and that the next calibrate step can be proceeded.

Related Command: [:SENSe]:CORRection:COLLect:STATus?
[:SENSe]:CORRection:COLLect:INITialize
[:SENSe]:CORRection:COLLect:OPEN
[:SENSe]:CORRection:COLLect:LOAD

[:SENSe]:CORRection:COLLect:STATus?**[INITialize | OPEN | SHORt | LOAD]**

Title: Calibration Status

Description: This command requests information about the current calibration step or the specified calibration step. If no calibration step is specified, then it returns a 1 if the current calibration step has completed, otherwise it returns a 0. If INITialized is specified, then the command returns a 1 if the Initialize step has completed and returns a 0 if it has not been completed. If OPEN is specified, then the command returns a 1 if the Open step has completed and returns a 0 if it has not been completed. If SHORt is specified, then the command returns a 1 if the Short step has completed and returns a 0 if it has not been completed. If LOAD is specified, then the command returns a 1 if the Load step has completed and returns a 0 if it has not been completed.

Parameter: INITialize | OPEN | SHORt | LOAD

Parameter Type: <char>

Range: INITialize | OPEN | SHORt | LOAD

Related Command: [:SENSe]:CORRection:COLLect:INITialize
 [:SENSe]:CORRection:COLLect:OPEN
 [:SENSe]:CORRection:COLLect:SHORt
 [:SENSe]:CORRection:COLLect:LOAD

[:SENSe]:CORRection:TYPE STANDARD | FLEX**[:SENSe]:CORRection:TYPE?**

Title: Calibration Type

Description: Set Calibration type - Standard, or Flex.

Parameter: STANDARD | FLEX

Parameter Type: <char>

Front Panel

Access: Shift-2 (Calibrate), Cal Type

[:SENSe]:FREQuency:CABLe <index>

Title: Cable Selection

Description: Sets the cable selection to the <index> in the cable list for the DTF measurement.

Parameter: <index>

Front Panel

Access: Freq/Dist, More, Cable (Note: For DTF measurements only.)

[:SENSE]:FREQUENCY:LINK UPLINK | DOWNLINK | UPANDDOWNLINK
[:SENSE]:FREQUENCY:LINK?

Title: Signal Standard Link

Description: Set “Link” signal standard parameter.

Parameter: UPLINK | DOWNLINK | UPANDDOWNLINK

Parameter Type: <char>

Front Panel

Access: Freq/Dist, Signal Standard, UpLink/DownLink/UpLink plus DownLink

[:SENSE]:FREQUENCY:SIGSTANDARD:NAME <string>
[:SENSE]:FREQUENCY:SIGSTANDARD:NAME?

Title: Signal Standard

Description: Selects the desired signal standard from the list. The <string> argument is the name of the desired signal standard as displayed in the instrument’s current signal standard list. The list can be seen on the instrument by choosing the Signal Standard submenu button in the Freq menu and then pressing the Select Standard submenu button in the Signal Standard menu. The list can also be downloaded remotely and viewed using Anritsu Master Software Tools. For example, if the desired Signal Standard is E-GSM 900(A) then the value of the <string> argument would be “P-GSM 900(A)”.

To select Uplink / Downlink / Uplink plus Downlink, use the command [:SENSE:]FREQUENCY:LINK.

The query form of this command will return the name of the currently-selected signal.

Standard on the list. To query the link status, use the command [:SENSE:]FREQUENCY:LINK?

Parameter: <string>

Front Panel

Access: Freq/Dist, Signal Standard, Select Standard

[:SENSe]:FREQUENCY:START <freq>

[:SENSe]:FREQUENCY:START?

Title: Start Frequency

Description: Sets the start frequency. Note that in the spectrum analyzer, changing the value of the start frequency will change the value of the coupled parameters, Center Frequency and Span. Note that in Cable & Antenna mode, changing the value of the start frequency may affect the DTF distance range.

Parameter: <freq>

Default Value: 2 MHz

Default Unit: Hz

Range: (based on model, refer to the instrument's User Guide)

Related Command: [:SENSe]:FREQUENCY:STOP?

Front Panel

Access: Freq/Dist, Start Freq

[:SENSe]:FREQUENCY:STOP <freq>

[:SENSe]:FREQUENCY:STOP?

Title: Stop Frequency

Description: Sets the stop frequency. Note that in the spectrum analyzer, changing the value of the stop frequency will change the value of the coupled parameters, Center Frequency and Span. Note that in Cable & Antenna mode, changing the value of the start frequency may affect the DTF distance range. Note that the set command is available only if the instrument is in Cable & Antenna mode.

Parameter: <freq>

Default Value: (based on model, refer to the instrument's User Guide)

Default Unit: Hz

Range: (based on model, refer to the instrument's User Guide)

```
[:SENSe]:SWEep:RESolution 137|275|551|1102|2204
[:SENSe]:SWEep:RESolution?
```

Title: Sweep Resolution

Description: This command sets the sweep resolution (in other words, the number of sweep data points). Valid resolution settings are 137, 275, 551, 1102, 2204.

Note Lower sweep resolutions yield faster sweep times.

Parameter: 137|275|551|1102|2204

Parameter Type: <char>

Default Value: 275

Front Panel

Access: Shift-3 (Sweep), Data Points

```
[:SENSe]:SWEep:RFIMmunity 0|1
[:SENSe]:SWEep:RFIMmunity?
```

Title: RF Immunity

Description: Sets RF Immunity. Set value to 1 for Low RF Immunity and 0 for High RF Immunity. Note that a sweep with RF immunity enabled will be slightly slower than a sweep with RF immunity disabled.

Parameter: 0|1

Parameter Type: <boolean>

Default Value: High

Front Panel

Access: Shift-3 (Sweep), RF Immunity

Appendix A — Examples

A-1 C/C++

This example is run on the command line. It sends the *IDN? query to the instrument and prints the response to the console.

```

// IdnExample.cpp : Microsoft Visual Studio-Generated Example
//   Based on Example 2-1 in the NI-VISA User Manual
//   Usage : IdnExample "USB0::0x0B58::0xFFF9::xxxxxxxx_xxx_xx::INSTR"
//   where xxxxxxxx_xxx_xx is the USB Device ID of the
//   instrument.
//   Output : The string identity string returned from the
//   instrument.
//   VISA Header : visa.h (must be included)
//   VISA Library : visa32.lib (must be linked with)

#include "stdafx.h"
#include "stdio.h"
#include "string.h"
#include "visa.h"

#define BUFFER_SIZE 255

int main(int argc, char* argv[])
{
    ViStatus status; /* For checking errors */
    ViSession defaultRM, instr; /* Communication channels */
    ViUInt32 retCount; /* Return count from string I/O */
    ViChar buffer[BUFFER_SIZE]; /* Buffer for string I/O */
    char tempDisplay[BUFFER_SIZE]; /* Display buffer for example */
    char *pAddress;

    /* Make sure we got our address. */
    if ( argc < 2 )
    {
        printf("Usage: IdnExample
\\\"USB0::0x0B58::0xFFF9::xxxxxxxx_xxx_xx::INSTR\"");
        printf("\t where xxxxxxxx_xxx_xx is the USB Device ID of your
instrument.\n");
        return -1;
    }
}

```

```
}

/* Store the address. */
pAddress = argv[1];

/* Begin by initializing the system*/
status = viOpenDefaultRM(&defaultRM);

if (status < VI_SUCCESS)
{
    /* Error Initializing VISA...exiting*/
    printf("Can't initialize VISA\n");
    return -1;
}

/* USB0::0x0B58::0xFFFF9::xxxxxxxx_xxx_xx::INSTR*/
/* NOTE: For simplicity, we will not show error checking*/
/* TODO: Add error handling. */
status = viOpen(defaultRM, pAddress, VI_NULL, VI_NULL, &instr);

/* Set the timeout for message-based communication*/
/* TODO: Add error handling. */
status = viSetAttribute(instr, VI_ATTR_TMO_VALUE, 120000);

/* Ask the device for identification */
sprintf(buffer, "*IDN?\n");
status = viWrite(instr, (unsigned char *)&buffer[0], 6, &retCount);
status = viRead(instr, (unsigned char *)buffer, BUFFER_SIZE,
&retCount);

/* TODO: Add code to process data. */
strncpy(tempDisplay, buffer, retCount);
tempDisplay[retCount] = 0; /* Null-terminate display string. */
printf("*IDN? Returned %d bytes: %s\n", retCount, tempDisplay);

/* Close down the system */
```

```
/* TODO: Add error handling. */  
status = viClose(instr);  
status = viClose(defaultRM);  
  
return 0;  
}
```

A-2 Visual Basic

This function can be called in a Visual Basic program. It sends the *IDN? query to the instrument and returns the byte count and ASCII response string.

Rem This example is based on Example 2-1 from the NI-VISA User Manual.

```
Public Sub IdnMain(ByVal address As String, ByRef byteCount As String,
ByRef returnBytes As String)
    Const BUFFER_SIZE = 200
    Dim stat As ViStatus
    Dim dfltRM As ViSession
    Dim sesn As ViSession
    Dim retCount As Long
    Dim buffer As String * BUFFER_SIZE

    Rem ***Include visa32.dll as a reference in your project.***

    Rem Begin by initializing the system
    stat = viOpenDefaultRM(dfltRM)
    If (stat < VI_SUCCESS) Then
        Rem Error initializing VISA...exiting
        MsgBox "Can't initialize VISA"
        Exit Sub
    End If

    Rem Open communication with Device
    Rem NOTE: For simplicity, we will not show error checking
    Rem TODO: Add error handling.
    stat = viOpen(dfltRM, address, VI_NULL, VI_NULL, sesn)

    Rem Set the timeout for message-based communication
    Rem TODO: Add error handling.
    stat = viSetAttribute(sesn, VI_ATTR_TMO_VALUE, 120000)

    Rem Ask the device for identification
    Rem TODO: Add error handling.
```

```
stat = viWrite(sesn, "*IDN?", 5, retCount)
stat = viRead(sesn, buffer, BUFFER_SIZE, retCount)
```

```
Rem TODO: Add code to process the data.
```

```
byteCount = retCount
```

```
returnBytes = Left(buffer, retCount)
```

```
Rem Close down the system
```

```
Rem TODO: Add error handling.
```

```
stat = viClose(sesn)
```

```
stat = viClose(dfltRM)
```

```
End Sub
```

A-3 Visual Basic

This function can be called in a Visual Basic program. It performs an RF Calibration in Cable & Antenna Analyzer mode. Communication with the instrument uses USB protocol.

```
Public Sub OnePathTwoPortCalibrationInCAAMode ()

    Const MAX_CNT = 200
    Dim stat As Variant
    Dim dfltRM As Variant
    Dim sesn As Variant
    Dim retCount As Long
    Dim Buffer As String * MAX_CNT
    Dim Response As String * VI_FIND_BUFLLEN
    Dim sInputString As String

    Rem Begin by initializing the system
    stat = viOpenDefaultRM(dfltRM)

    If (stat < VI_SUCCESS) Then
        Rem Error initializing VISA...exiting
        Exit Sub
    End If

    Rem Open communication with USB Protocol
    Rem NOTE: For simplicity, we will not show error checking
    Rem 0x0B5B::0xFF60::32850021_76227-3_102 = Vendor id::Product
    id::dut usb id
    stat = viOpen(dfltRM,
    "USB0::0x0B5B::0xFF60::32850021_76227-3_102::INSTR", VI_NULL, VI_NULL,
    sesn)

    Rem Set some visa attributes
    stat = viSetAttribute(sesn, VI_ATTR_TMO_VALUE, 90000)
    stat = viSetAttribute(sesn, VI_ATTR_SEND_END_EN, VI_TRUE)
    stat = viSetAttribute(sesn, VI_ATTR_SUPPRESS_END_EN, VI_FALSE)
    stat = viClear(sesn)

    'Switch to Cable-Antenna Analyzer Mode
```

```
sInputString = ":INST:NSEL 2"
stat = viWrite(sesn, sInputString, Len(sInputString), retCount)
Do
    Sleep (200)
    sInputString = ":INST:NSEL?"
    stat = viWrite(sesn, sInputString, Len(sInputString), retCount)
    stat = viRead(sesn, Buffer, MAX_CNT, retCount)
Loop Until Val(Buffer) = 2

'System preset
sInputString = ":SYSTEM:PRESET"
stat = viWrite(sesn, sInputString, Len(sInputString), retCount)

'Wait for previous operation to be completed
sInputString = "*OPC?"
stat = viWrite(sesn, sInputString, Len(sInputString), retCount)
Buffer = ""
stat = viRead(sesn, Buffer, MAX_CNT, retCount)

'Set start frequency
sInputString = ":SENSe:FREQuency:StARt 2 MHz"
stat = viWrite(sesn, sInputString, Len(sInputString), retCount)

'Set stop frequency
sInputString = "SENSe:FREQuency:StOP 7 GHz"
stat = viWrite(sesn, sInputString, Len(sInputString), retCount)

'Set IFBW in Hz
sInputString = "SWEep:IFBW 1000"
stat = viWrite(sesn, sInputString, Len(sInputString), retCount)

'Initiate One-path Two-port Calibration
sInputString = "SENSe:CORRection:COLLect:TYPE 2PPF"
stat = viWrite(sesn, sInputString, Len(sInputString), retCount)

'Wait for previous operation to be completed
```

```
sInputString = "*OPC?"
stat = viWrite(sesn, sInputString, Len(sInputString), retCount)
Buffer = ""
stat = viRead(sesn, Buffer, MAX_CNT, retCount)

'measure open
MsgBox "Connect open at port 1"

sInputString = ":SENS:CORR:COLL:ACQU OPEN, 1"
stat = viWrite(sesn, sInputString, Len(sInputString), retCount)
Do
    Sleep (200)
    'wait open measurement to complete and returns 1
    sInputString = ":SENS:CORR:COLL:ACQU:STAT? OPEN, 1"
    stat = viWrite(sesn, sInputString, Len(sInputString), retCount)
    stat = viRead(sesn, Buffer, MAX_CNT, retCount)
Loop Until Val(Buffer) = 1

'measure short
MsgBox "Connect short at port 1"

sInputString = ":SENS:CORR:COLL:ACQU SHORT, 1"
stat = viWrite(sesn, sInputString, Len(sInputString), retCount)
Do
    Sleep (200)
    'wait short measurement to complete and returns 1
    sInputString = ":SENS:CORR:COLL:ACQU:STAT? SHORT, 1"
    stat = viWrite(sesn, sInputString, Len(sInputString), retCount)
    stat = viRead(sesn, Buffer, MAX_CNT, retCount)
Loop Until Val(Buffer) = 1

'measure load
MsgBox "Connect load at port 1"

sInputString = ":SENS:CORR:COLL:ACQU LOAD, 1"
stat = viWrite(sesn, sInputString, Len(sInputString), retCount)
```

```
Do
    Sleep (200)
    'wait load measurement to complete and returns 1
    sInputString = ":SENS:CORR:COLL:ACQU:STAT? LOAD, 1"
    stat = viWrite(sesn, sInputString, Len(sInputString), retCount)
    stat = viRead(sesn, Buffer, MAX_CNT, retCount)
Loop Until Val(Buffer) = 1

'measure forward isolation
sInputString = ":SENS:CORR:COLL:ACQU ISOL, 1"
stat = viWrite(sesn, sInputString, Len(sInputString), retCount)
Do
    Sleep (200)
    'wait forward isolation measurement to complete and returns 1
    sInputString = ":SENS:CORR:COLL:ACQU:STAT? ISOL, 1"
    stat = viWrite(sesn, sInputString, Len(sInputString), retCount)
    stat = viRead(sesn, Buffer, MAX_CNT, retCount)
Loop Until Val(Buffer) = 1

'measure thru
MsgBox "Connect thru between port 1 & 2."

sInputString = ":SENS:CORR:COLL:ACQU THRU, 1"
stat = viWrite(sesn, sInputString, Len(sInputString), retCount)
Do
    Sleep (200)
    'wait thru measurement to complete and returns 1
    sInputString = ":SENS:CORR:COLL:ACQU:STAT? THRU, 1"
    stat = viWrite(sesn, sInputString, Len(sInputString), retCount)
    stat = viRead(sesn, Buffer, MAX_CNT, retCount)
Loop Until Val(Buffer) = 1

'Save and apply calibration
sInputString = ":SENS:CORR:COLL:SAV"
stat = viWrite(sesn, sInputString, Len(sInputString), retCount)
```

```
'Wait for previous operation to be completed
sInputString = "*OPC?"
stat = viWrite(sesn, sInputString, Len(sInputString), retCount)
Buffer = ""
stat = viRead(sesn, Buffer, MAX_CNT, retCount)

'read back the cal type (i.e. Buffer = 5, One-path Two-port
calibration)
sInputString = "SENS:CAL:STAT?"
stat = viWrite(sesn, sInputString, Len(sInputString), retCount)
Buffer = ""
stat = viRead(sesn, Buffer, MAX_CNT, retCount)

Rem Close down the system
stat = viClose(sesn)
stat = viClose(dfltRM)
End Sub
```

A-4 Visual Basic

This function can be called in a Visual Basic program. It demonstrates connection and setting parameters in the instrument while using Ethernet Socket protocol.

```
Public Sub CommunicationWithTCPIPsocket()
```

```
    Const MAX_CNT = 200
```

```
    Dim stat As Variant
```

```
    Dim dfltRM As Variant
```

```
    Dim sesn As Variant
```

```
    Dim retCount As Long
```

```
    Dim Buffer As String * MAX_CNT
```

```
    Dim Response As String * VI_FIND_BUFLEN
```

```
    Dim sInputString As String
```

```
    Dim ipAddress As String
```

```
    Dim Port As String
```

```
    Rem Begin by initializing the system
```

```
    stat = viOpenDefaultRM(dfltRM)
```

```
    If (stat < VI_SUCCESS) Then
```

```
        Rem Error initializing VISA...exiting
```

```
        Exit Sub
```

```
    End If
```

```
    Rem Open communication with Ethernet Socket Protocol
```

```
    Rem before open an new Ethernet session make sure session was closed
```

```
    Rem NOTE: For simplicity, we will not show error checking
```

```
    'address and port
```

```
    'this sample address
```

```
    ipAddress = "172.26.202.117"
```

```
    'For MW82119B port will be 9001
```

```
    Port = "9001"
```

```
stat = viOpen(dfltRM, "TCPIP0:" & ipAddress & "::" & Port &
"::SOCKET", VI_NULL, VI_NULL, sesn)
```

```
Rem Set some visa attributes
```

```
Rem recommendation timeout >= 90 sec
```

```
stat = viSetAttribute(sesn, VI_ATTR_TMO_VALUE, 90000)
```

```
stat = viSetAttribute(sesn, VI_ATTR_SEND_END_EN, VI_TRUE)
```

```
Rem VI_ATTR_SUPPRESS_END_EN has to set to False during Ethernet
Socket communication
```

```
stat = viSetAttribute(sesn, VI_ATTR_SUPPRESS_END_EN, VI_FALSE)
```

```
stat = viClear(sesn)
```

```
Rem NOTE:
```

```
Rem All commands (SCPI) must be send with linefeed
```

```
Rem during Ethernet Socket communication
```

```
Rem i.e. "vbLf" is in Visual Basic environment constant
```

```
'read back the strat frequency
```

```
sInputString = "*IDN?" & vbLf
```

```
stat = viWrite(sesn, sInputString, Len(sInputString), retCount)
```

```
Buffer = ""
```

```
stat = viRead(sesn, Buffer, MAX_CNT, retCount)
```

```
'System preset
```

```
sInputString = ":SYSTEM:PRESET" & vbLf
```

```
stat = viWrite(sesn, sInputString, Len(sInputString), retCount)
```

```
'Wait for previous operation to be completed
```

```
sInputString = "*OPC?" & vbLf
```

```
stat = viWrite(sesn, sInputString, Len(sInputString), retCount)
```

```
Buffer = ""
```

```
stat = viRead(sesn, Buffer, MAX_CNT, retCount)
```

```
'Set start frequency
```

```
sInputString = ":SENSE:FREQuency:START 1 GHz" & vbLf
```

```
stat = viWrite(sesn, sInputString, Len(sInputString), retCount)

'read back the strat frequency
sInputString = ":SENSe:FREQuency:START?" & vbLf
stat = viWrite(sesn, sInputString, Len(sInputString), retCount)
Buffer = ""
stat = viRead(sesn, Buffer, MAX_CNT, retCount)

'Set stop frequency
sInputString = "SENSe:FREQuency:STOP 7 GHz" & vbLf
stat = viWrite(sesn, sInputString, Len(sInputString), retCount)

'read back the stop frequency
sInputString = ":SENSe:FREQuency:STOP?" & vbLf
stat = viWrite(sesn, sInputString, Len(sInputString), retCount)
Buffer = ""
stat = viRead(sesn, Buffer, MAX_CNT, retCount)

Rem Close down the system
stat = viClose(sesn)
stat = viClose(dfltRM)

End Sub
```

A-5 LabVIEW™

This example shows how to read the trace data from the instrument in 32-bit integer format. The output is an array of data point magnitudes. Figure 1 shows the data capture and conversion to 32-bit integers in the format used by LabVIEW. Figure 2 shows the details of the conversion.

Note	Your instrument must first be defined to the VISA resource manager using NI-MAX. The VISA resource for your instrument serves as the VISA resource input to the vi.
-------------	---

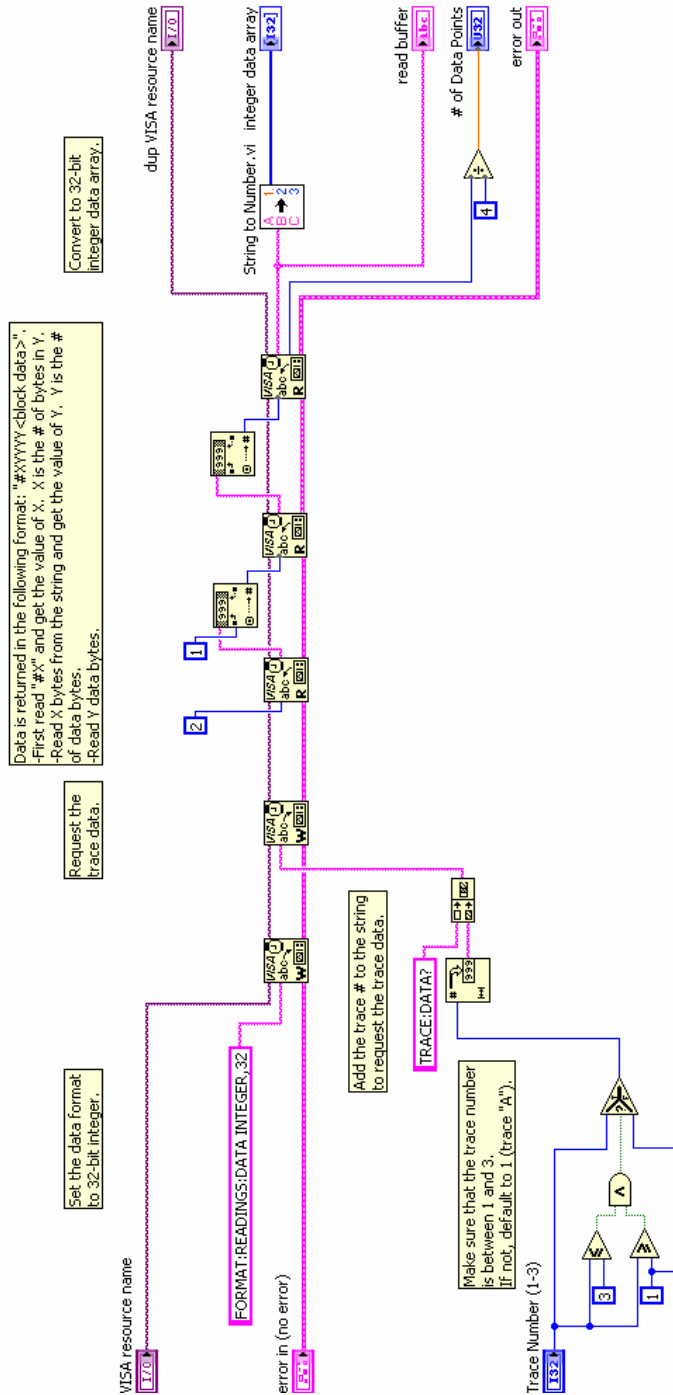

Figure A-1. Data Capture

String To Number.vi

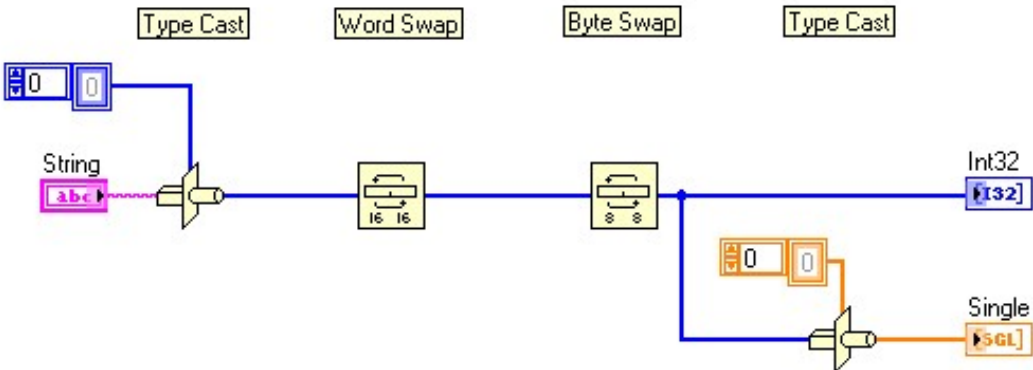

Figure A-2. Data Conversion

Appendix B — PIM Carrier Bands

B-1 Introduction

PIM tests are conducted by transmitting two test signals, F1 and F2, into the system under test and then measuring intermodulation products created by those test signals that fall within the receive band of the system. The PIM Master transmit signals are user adjustable within the range shown in [Table B-1](#).

B-2 PIM Master Carrier Bands

Table B-1. PIM Master Carrier Bands and Frequencies

Carrier Band	Frequency Range		Option Number	Rx Frequency Range, MHz
	F1	F2		
LTE 700 MHz Lower Band	734 MHz to 734.5 MHz	752 MHz to 768 MHz	MW82119B-0700	698 to 717
LTE 700 MHz Upper Band	734 MHz to 734.5 MHz	746 MHz to 766 MHz	MW82119B-0700	777 to 806
APT 700 MHz Lower Band	734 MHz to 734.5 MHz	752 MHz to 768 MHz	MW82119B-0701	698 to 717
APT 700 MHz Upper Band	734 MHz to 734.5 MHz	746 MHz to 766 MHz	MW82119B-0701	777 to 806
LTE 800 MHz	791 MHz to 795 MHz	811.5 MHz to 821 MHz	MW82119B-0800	832 to 862
Cellular 850 MHz	869 MHz to 871 MHz	881.5 MHz to 894 MHz	MW82119B-0850	824 to 849
E-GSM 900 MHz	925 MHz to 937.5 MHz	951.5 MHz to 960 MHz	MW82119B-0900	880 to 915
DCS 1800 MHz	1805 MHz to 1837 MHz	1857.5 MHz to 1880 MHz	MW82119B-0180	1710 to 1785
PCS 1900 MHz	1930 MHz to 1945 MHz	1955 MHz to 1995 MHz	MW82119B-0194	1850 to 1910
PCS/AWS 1900/2100 MHz	1930 MHz to 1945 MHz	2110 MHz to 2155 MHz	MW82119B-0194	1710 to 1755
UMTS 2100 MHz	2110 MHz to 2112.5 MHz	2130 MHz to 2170 MHz	MW82119B-0210	1920 to 1980 (IM7) 2050 to 2090 (IM3)
LTE 2600 MHz	2620 MHz to 2630 MHz	2650 MHz to 2690 MHz	MW82119B-0260	2500 to 2570

Appendix C — List of Commands by Mode

Chapter 1—General Information

Chapter 2—Programming with SCPI

Chapter 3—All Modes Programming Commands

:FETCh:GPS?	3-2
:INSTrument:CATalog:FULL?	3-3
:INSTrument:NSElect <integer>	
:INSTrument:NSElect?	3-3
:INSTrument[:SElect] <string>	
:INSTrument[:SElect]?	3-4
:MMEMory:DATA? <file name>	3-5
:MMEMory:MSIS INTernal USB	
:MMEMory:MSIS?	3-5
:MMEMory:MSIS:COpy	3-6
:MMEMory:MSIS:DEStination INTernal USB	
:MMEMory:MSIS:DEStination?	3-7
:MMEMory:STORe:JPEG <file name>	3-7
[[:SENSE]:GPS	
[[:SENSE]:GPS?	3-8
[[:SENSE]:GPS:RESet	3-8
[[:SENSE]:GPS:CURRent?	3-9
[[:SENSE]:GPS:VOLTage 0 1	
[[:SENSE]:GPS:VOLTage?	3-9
:SYSTem:OPTions?	3-10
:SYSTem:PRESet.	3-10

Chapter 4—PIM Analyzer Programming Commands

:CALCulate:DTPMeas:CABLoss	
:CALCulate:DTPMeas:CABLoss?	4-2
:CALCulate:DTPMeas:DISPlay:RESOLution	
:CALCulate:DTPMeas:DISPlay:RESOLution?	4-2
:CALCulate:DTPMeas:DMAX?	4-3
:CALCulate:DTPMeas:FRESolution?	4-3
:CALCulate:DTPMeas:PVELocity	
:CALCulate:DTPMeas:PVELocity?	4-4
:CALCulate:DTPMeas:REFerence:AMPLitude	
:CALCulate:DTPMeas:REFerence:AMPLitude?	4-4
:CALCulate:DTPMeas:REFerence[:STATe] OFF ON 0 1	
:CALCulate:DTPMeas:REFerence[:STATe]?	4-5
:CALCulate:DTPMeas:STARt	
:CALCulate:DTPMeas:STARt?	4-6
:CALCulate:DTPMeas:STOP	

:CALCulate:DTPMeas:STOP?	4-6
:CALCulate:DTPMeas:UNIT METers FEET	
:CALCulate:DTPMeas:UNIT?	4-7
:CALCulate:DTPMeas:WINDow	
:CALCulate:DTPMeas:WINDow?	4-7
:CALCulate:LIMit:ALARm ON OFF 0 1	
:CALCulate:LIMit:ALARm?	4-8
:CALCulate:LIMit:AMPLitude	
:CALCulate:LIMit:AMPLitude?	4-8
:CALCulate:LIMit:FAIL?	4-9
:CALCulate:LIMit[:STATe] OFF ON 0 1	
:CALCulate:LIMit[:STATe]?	4-9
:CALCulate:LIMit:TYPE	
:CALCulate:LIMit:TYPE?	4-10
:CALCulate:LIMit:VALue	4-10
:CALCulate:MARKer:AOFF	4-10
:CALCulate:MARKer{1 2 3 4 5 6}:DELTA[:STATe] OFF ON 0 1	
:CALCulate:MARKer{1 2 3 4 5 6}:DELTA[:STATe]?	4-11
:CALCulate:MARKer{1 2 3 4 5 6}:DELTA:TRACe 0 1	
:CALCulate:MARKer{1 2 3 4 5 6}:DELTA:TRACe?	4-12
:CALCulate:MARKer{1 2 3 4 5 6}:DELTA:X <x-parameter>	
:CALCulate:MARKer{1 2 3 4 5 6}:DELTA:X?	4-12
:CALCulate:MARKer{1 2 3 4 5 6}:DELTA:Y?	4-13
:CALCulate:MARKer{1 2 3 4 5 6}[:STATe] OFF ON 0 1	
:CALCulate:MARKer{1 2 3 4 5 6}[:STATe]?	4-13
:CALCulate:MARKer{1 2 3 4 5 6}:TRACe 0 1	
:CALCulate:MARKer{1 2 3 4 5 6}:TRACe?	4-14
:CALCulate:MARKer{1 2 3 4 5 6}:X <x-parameter>	
:CALCulate:MARKer{1 2 3 4 5 6}:X?	4-15
:CALCulate:MARKer{1 2 3 4 5 6}:Y?	4-16
:CALCulate:SCALE:UNIT DBM DBC	
:CALCulate:SCALE:UNIT?	4-16
:CALCulate:SPECTrum:MAXHold	
:CALCulate:SPECTrum:MAXHold?	4-17
CALibration:PIManalyzer:FULL	
CALibration:PIManalyzer:FULL?	4-18
DISPlay:WINDow:Trace:Y[:SCALE]:PDIVision	
DISPlay:WINDow:Trace:Y[:SCALE]:PDIVision?	4-19
DISPlay:WINDow:Trace:Y[:SCALE]:RLEVel	
DISPlay:WINDow:Trace:Y[:SCALE]:RLEVel?	4-19
INITiate:PIManalyzer:MEASure OFF ON 0 1	4-20
INITiate:PIManalyzer:PVT:ALLPower:CAL	4-20
INITiate:PIManalyzer:RESidual:CAL	4-20
MMEMemory:CABLeList:RESet	4-21
MMEMemory:LOAD:TRACe <integer>,<file name>	4-21
MMEMemory:STORE:TRACe <integer>,<file name>	4-22
MMEMemory:LOAD:STATe <integer>,<file name>	4-22
MMEMemory:STORE:STATe <integer>,<file name>	4-23
[:SENSe]:DTPMeas:AVERAge:TYPE	
[:SENSe]:DTPMeas:AVERAge:TYPE?	4-24

Appendix C — List of Commands by Mode

[SENSe]:DTPMeas:DISPlay:BOTTom	
[SENSe]:DTPMeas:DISPlay:BOTTom?	4-24
[SENSe]:DTPMeas:DISPlay:TOP	
[SENSe]:DTPMeas:DISPlay:TOP?	4-25
[SENSe]:DTPMeas:ENREsolution ON OFF	
[SENSe]:DTPMeas:ENREsolution?	4-25
[SENSe]:PIManalyzer:AVERaging FAST LOWNoise	
[SENSe]:PIManalyzer:AVERaging?	4-26
[SENSe]:PIManalyzer:AUTorange OFF ON 0 1	
[SENSe]:PIManalyzer:AUTorange?	4-26
[SENSe]:PIManalyzer:DTPMeas:LRDTf:STATe]	
[SENSe]:PIManalyzer:DTPMeas:LRDTf:STATe]?	4-27
[SENSe]:PIManalyzer:DTPMeas:LRDTf:STARt?	4-27
[SENSe]:PIManalyzer:DTPMeas:LRDTf:STOP?	4-27
[SENSe]:PIManalyzer:FREQuency:F1 2	
[SENSe]:PIManalyzer:FREQuency:F1 2?	4-28
[SENSe]:PIManalyzer:FREQuency:STEP	
[SENSe]:PIManalyzer:FREQuency:STEP?	4-28
[SENSe]:PIManalyzer:HIReflection:BYPass	
[SENSe]:PIManalyzer:HIReflection:BYPass?	4-29
[SENSe]:PIManalyzer:IMD:ORDer	
[SENSe]:PIManalyzer:IMD:ORDer?	4-29
[SENSe]:PIManalyzer:IMFReq:BAND LOW HIGH	
[SENSe]:PIManalyzer:IMFReq:BAND?	4-30
[SENSe]:PIManalyzer:MEASure:STATus?	4-30
[SENSe]:PIManalyzer:MEASure:VALue?	4-31
[SENSe]:PIManalyzer:MODE PIM PIMSwp DTP SPECTRUM_VIEW	
[SENSe]:PIManalyzer:MODE?	4-31
[SENSe]:PIManalyzer:OUTPut:POWer	
[SENSe]:PIManalyzer:OUTPut:POWer?	4-32
[SENSe]:PIManalyzer:RF:OUTput ON OFF	
[SENSe]:PIManalyzer:RF:OUTput?	4-32
[SENSe]:PIManalyzer:SPECTrum:CURRent:MEASure:VALue?	4-33
[SENSe]:PIManalyzer:SPECTrum:CURRent:FREQuency?	4-33
[SENSe]:PIManalyzer:SPECTrum:MAX:MEASure:VALue?	4-33
[SENSe]:PIManalyzer:SPECTrum:MAX:FREQuency?	4-34
[SENSe]:PIManalyzer:SWEEp:FREQuency:F1 2?	4-34
[SENSe]:PIManalyzer:SWEEp:FREQuency:F1:STARt	
[SENSe]:PIManalyzer:SWEEp:FREQuency:F1:STARt?	4-35
[SENSe]:PIManalyzer:SWEEp:FREQuency:F1:STOP	
[SENSe]:PIManalyzer:SWEEp:FREQuency:F1:STOP?	4-35
[SENSe]:PIManalyzer:SWEEp:FREQuency:F2:STARt	
[SENSe]:PIManalyzer:SWEEp:FREQuency:F2:STARt?	4-36
[SENSe]:PIManalyzer:SWEEp:FREQuency:F2:STOP	
[SENSe]:PIManalyzer:SWEEp:FREQuency:F2:STOP?	4-36
[SENSe]:PIManalyzer:SWEEp:IMD:ORDer	
[SENSe]:PIManalyzer:SWEEp:IMD:ORDer?	4-37
[SENSe]:PIManalyzer:TEST:DURation	
[SENSe]:PIManalyzer:TEST:DURation?	4-37
:TRACe[:DATA]? <X>	4-38

Chapter 5—Cable & Antenna Commands

:CALCulate:LIMit:ALARm OFF ON 0 1	
:CALCulate:LIMit:ALARm?	5-1
:CALCulate:LIMit:CLEar	5-1
:CALCulate:LIMit:POINt:ADD	5-1
:CALCulate:LIMit:POINt:FREQuency <freq>	
:CALCulate:LIMit:POINt:FREQuency?	5-2
:CALCulate:LIMit:POINt:VALue <value>	
:CALCulate:LIMit:POINt:VALue?	5-2
:CALCulate:LIMit:POINt?	5-2
:CALCulate:LIMit[:STATe] OFF ON 0 1	
:CALCulate:LIMit[:STATe]?	5-3
:CALCulate:MARKer:AOFF	5-3
:CALCulate:MARKer:TABLE:DATA?	5-4
:CALCulate:MARKer:TABLE[:STATe] OFF ON 0 1	
:CALCulate:MARKer:TABLE[:STATe]?	5-4
:CALCulate:MARKer{1 2 3 4 5 6}:DELTA:X <x-parameter>	
:CALCulate:MARKer{1 2 3 4 5 6}:DELTA:X?	5-5
:CALCulate:MARKer{1 2 3 4 5 6}:DELTA:Y?	5-5
:CALCulate:MARKer{1 2 3 4 5 6}:DELTA[:STATe] OFF ON 0 1	
:CALCulate:MARKer{1 2 3 4 5 6}:DELTA[:STATe]?	5-5
:CALCulate:MARKer{1 2 3 4 5 6}:PEAK	5-6
:CALCulate:MARKer{1 2 3 4 5 6}:VALley	5-6
:CALCulate:MARKer{1 2 3 4 5 6}:X <x-parameter>	
:CALCulate:MARKer{1 2 3 4 5 6}:X?	5-6
:CALCulate:MARKer{1 2 3 4 5 6}:Y?	5-6
:CALCulate:MARKer{1 2 3 4 5 6}[:STATe] OFF ON 0 1	
:CALCulate:MARKer{1 2 3 4 5 6}[:STATe]?	5-7
:CALCulate:MATH:FUNcTION NORMAl ADD SUBTRACT	
:CALCulate:MATH:FUNcTION?	5-7
:CALCulate:MATH:MEMorize	5-7
:CALCulate:MATH:OVERlay ON OFF	5-8
:CALCulate:SMOothing <integer>	
:CALCulate:SMOothing?	5-8
:CALCulate:TRANSform:CLAVerage?	5-8
:CALCulate:TRANSform:DISTance:CABLoss	
:CALCulate:TRANSform:DISTance:CABLoss?	5-8
:CALCulate:TRANSform:DISTance:DMAx?	5-9
:CALCulate:TRANSform:DISTance:FRESolution?	5-9
:CALCulate:TRANSform:DISTance:PVELocity	
:CALCulate:TRANSform:DISTance:PVELocity?	5-9
:CALCulate:TRANSform:DISTance:START	
:CALCulate:TRANSform:DISTance:START?	5-9
:CALCulate:TRANSform:DISTance:STOP	
:CALCulate:TRANSform:DISTance:STOP?	5-10

Appendix C — List of Commands by Mode

:CALCulate:TRANSform:DISTance:UNIT METers FEET	
:CALCulate:TRANSform:DISTance:UNIT?	5-10
:CALCulate:TRANSform:DISTance:WINDow RECTangular MSLobe NSLobe LSLobe	
:CALCulate:TRANSform:DISTance:WINDow?	5-10
:CALibration:STATe?	5-11
:CONFigure:MEASure?	5-12
:CONFigure:MEASure:ACTiveChan 0 1	
:CONFigure:MEASure:ACTiveChan?	5-12
:CONFigure:MEASure:DUALdisplay DUAL SINGLE	
:CONFigure:MEASure:DUALdisplay?	5-12
:CONFigure:MEASure:RLDTf	5-12
:CONFigure:MEASure:RLFReq	5-13
:CONFigure:MEASure:1PHase	5-13
:CONFigure:MEASure:SMCHart	5-13
:CONFigure:MEASure:SWRDtf	5-13
:DISPlay:WINDow:TRACe:Y[:SCALe]:AUToscale	5-14
:DISPlay:WINDow:TRACe:Y[:SCALe]:BOTTOm <value>	5-14
:DISPlay:WINDow:TRACe:Y[:SCALe]:TOP <value>	5-14
:DISPlay:WINDow:TRACe:Y[:SCALe]:SMCHart 0 10 20 30 -3	
:DISPlay:WINDow:TRACe:Y[:SCALe]:SMCHart?	5-15
:FORMat[:READings][:DATA] ASCii INTEger,32 REAL,32	
:FORMat[:READings][:DATA]?	5-16
:INITiate:CONTInuous OFF ON 0 1	
:INITiate:CONTInuous?	5-19
:INITiate:HOLD OFF ON 0 1	
:INITiate:HOLD?	5-19
:INITiate[:IMMediate]	5-20
:MMEMory:DELeTe <file name>	5-21
:MMEMory:LOAD:STATe <integer>,<file name>	5-21
:MMEMory:LOAD:TRACe <integer>,<file name>	5-22
:MMEMory:STORE:STATe <integer>,<file name>	5-22
:MMEMory:STORE:TRACe <integer>,<file name>	5-23
:TRACe:PREAmble? [1]	5-24
:TRACe[:DATA]? [1]	5-24
[:SENSe]:AVERAge:CLear	5-25
[:SENSe]:AVERAge:COUNT <integer>	
[:SENSe]:AVERAge:COUNT?	5-25
[:SENSe]:AVERAge[:STATe] OFF ON 0 1	
[:SENSe]:AVERAge[:STATe]?	5-25
[:SENSe]:CORRection:COLLect:ABORT	5-26
[:SENSe]:CORRection:COLLect:INITialize	5-26
[:SENSe]:CORRection:COLLect:LOAD	5-26
[:SENSe]:CORRection:COLLect:OPEN	5-27

[:SENSe]:CORRection:COLLect:SHORT.	5-27
[:SENSe]:CORRection:COLLect:STATus? [INITialize OPEN SHORT LOAD].	5-28
[:SENSe]:CORRection:TYPE STANDARD FLEX [:SENSe]:CORRection:TYPE?	5-28
[:SENSe]:FREQuency:CABLe <index>	5-28
[:SENSe]:FREQuency:LINK UPLINK DOWNLINK UPANDDWNLINK [:SENSe]:FREQuency:LINK?	5-29
[:SENSe]:FREQuency:SIGStandard:NAME <string> [:SENSe]:FREQuency:SIGStandard:NAME?	5-29
[:SENSe]:FREQuency:STARt <freq> [:SENSe]:FREQuency:STARt?	5-30
[:SENSe]:FREQuency:STOP <freq> [:SENSe]:FREQuency:STOP?	5-30
[:SENSe]:SWEep:RESolution 137 275 551 1102 2204 [:SENSe]:SWEep:RESolution?	5-31
[:SENSe]:SWEep:RFIMmunity 0 1 [:SENSe]:SWEep:RFIMmunity?	5-31

Appendix D — List of Commands, Alphabetical

All SCPI Commands in Alphabetic List

:CALCulate:DTPMeas:CABLoss	
:CALCulate:DTPMeas:CABLoss?	4-2
:CALCulate:DTPMeas:DISPlay:RESOLution	
:CALCulate:DTPMeas:DISPlay:RESOLution?	4-2
:CALCulate:DTPMeas:DMAX?	4-3
:CALCulate:DTPMeas:FRESolution?	4-3
:CALCulate:DTPMeas:PVELocity	
:CALCulate:DTPMeas:PVELocity?	4-4
:CALCulate:DTPMeas:REFerence:AMPLitude	
:CALCulate:DTPMeas:REFerence:AMPLitude?	4-4
:CALCulate:DTPMeas:REFerence[:STATe] OFF ON 0 1	
:CALCulate:DTPMeas:REFerence[:STATe]?	4-5
:CALCulate:DTPMeas:START	
:CALCulate:DTPMeas:START?	4-6
:CALCulate:DTPMeas:STOP	
:CALCulate:DTPMeas:STOP?	4-6
:CALCulate:DTPMeas:UNIT METers FEET	
:CALCulate:DTPMeas:UNIT?	4-7
:CALCulate:DTPMeas:WINDow	
:CALCulate:DTPMeas:WINDow?	4-7
:CALCulate:LIMit:ALARm OFF ON 0 1	
:CALCulate:LIMit:ALARm?	5-1
:CALCulate:LIMit:ALARm ON OFF 0 1	
:CALCulate:LIMit:ALARm?	4-8
:CALCulate:LIMit:AMPLitude	
:CALCulate:LIMit:AMPLitude?	4-8
:CALCulate:LIMit:CLEar	5-1
:CALCulate:LIMit:FAIL?	4-9
:CALCulate:LIMit:POINt:ADD	5-1
:CALCulate:LIMit:POINt:FREQuency <freq>	
:CALCulate:LIMit:POINt:FREQuency?	5-2
:CALCulate:LIMit:POINt:VALue <value>	
:CALCulate:LIMit:POINt:VALue?	5-2
:CALCulate:LIMit:POINt?	5-2
:CALCulate:LIMit:TYPE	
:CALCulate:LIMit:TYPE?	4-10
:CALCulate:LIMit:VALue	4-10
:CALCulate:LIMit[:STATe] OFF ON 0 1	
:CALCulate:LIMit[:STATe]?	5-3
:CALCulate:LIMit[:STATe] OFF ON 0 1	
:CALCulate:LIMit[:STATe]?	4-9
:CALCulate:MARKer:AOFF	4-10
:CALCulate:MARKer:AOFF	5-3

:CALCulate:MARKer:TABLE:DATA?	5-4
:CALCulate:MARKer:TABLE[:STATe] OFF ON 0 1	
:CALCulate:MARKer:TABLE[:STATe]?	5-4
:CALCulate:MARKer{1 2 3 4 5 6}:DELTA:TRACe 0 1	
:CALCulate:MARKer{1 2 3 4 5 6}:DELTA:TRACe?	4-12
:CALCulate:MARKer{1 2 3 4 5 6}:DELTA:X <x-parameter>	
:CALCulate:MARKer{1 2 3 4 5 6}:DELTA:X?	4-12
:CALCulate:MARKer{1 2 3 4 5 6}:DELTA:X <x-parameter>	
:CALCulate:MARKer{1 2 3 4 5 6}:DELTA:X?	5-5
:CALCulate:MARKer{1 2 3 4 5 6}:DELTA:Y?	4-13
:CALCulate:MARKer{1 2 3 4 5 6}:DELTA:Y?	5-5
:CALCulate:MARKer{1 2 3 4 5 6}:DELTA[:STATe] OFF ON 0 1	
:CALCulate:MARKer{1 2 3 4 5 6}:DELTA[:STATe]?	5-5
:CALCulate:MARKer{1 2 3 4 5 6}:DELTA[:STATe] OFF ON 0 1	
:CALCulate:MARKer{1 2 3 4 5 6}:DELTA[:STATe]?	4-11
:CALCulate:MARKer{1 2 3 4 5 6}:PEAK	5-6
:CALCulate:MARKer{1 2 3 4 5 6}:TRACe 0 1	
:CALCulate:MARKer{1 2 3 4 5 6}:TRACe?	4-14
:CALCulate:MARKer{1 2 3 4 5 6}:VALley	5-6
:CALCulate:MARKer{1 2 3 4 5 6}:X <x-parameter>	
:CALCulate:MARKer{1 2 3 4 5 6}:X?	4-15
:CALCulate:MARKer{1 2 3 4 5 6}:X <x-parameter>	
:CALCulate:MARKer{1 2 3 4 5 6}:X?	5-6
:CALCulate:MARKer{1 2 3 4 5 6}:Y?	4-16
:CALCulate:MARKer{1 2 3 4 5 6}:Y?	5-6
:CALCulate:MARKer{1 2 3 4 5 6}[:STATe] OFF ON 0 1	
:CALCulate:MARKer{1 2 3 4 5 6}[:STATe]?	5-7
:CALCulate:MARKer{1 2 3 4 5 6}[:STATe] OFF ON 0 1	
:CALCulate:MARKer{1 2 3 4 5 6}[:STATe]?	4-13
:CALCulate:MATH:FUNCTioN NORMAl ADD SUBTRACT	
:CALCulate:MATH:FUNCTioN?	5-7
:CALCulate:MATH:MEMorize	5-7
:CALCulate:MATH:OVERlay ON OFF	5-8
:CALCulate:SCALE:UNIT DBM DBC	
:CALCulate:SCALE:UNIT?	4-16
:CALCulate:SMOothing <integer>	
:CALCulate:SMOothing?	5-8
:CALCulate:SPECTrum:MAXHold	
:CALCulate:SPECTrum:MAXHold?	4-17
:CALCulate:TRANSform:CLAVerage?	5-8
:CALCulate:TRANSform:DISTance:CABLoss	
:CALCulate:TRANSform:DISTance:CABLoss?	5-8
:CALCulate:TRANSform:DISTance:DMAX?	5-9
:CALCulate:TRANSform:DISTance:FRESolution?	5-9
:CALCulate:TRANSform:DISTance:PVELocity	
:CALCulate:TRANSform:DISTance:PVELocity?	5-9
:CALCulate:TRANSform:DISTance:START	
:CALCulate:TRANSform:DISTance:START?	5-9
:CALCulate:TRANSform:DISTance:STOP	
:CALCulate:TRANSform:DISTance:STOP?	5-10

Appendix D — List of Commands, Alphabetical

:CALCulate:TRANSform:DISTance:UNIT METers FEET	
:CALCulate:TRANSform:DISTance:UNIT?	5-10
:CALCulate:TRANSform:DISTance:WINDow RECTangular MSLobe NSLobe LSLobe	
:CALCulate:TRANSform:DISTance:WINDow?	5-10
:CALibration:PIManalyzer:FULL	
:CALibration:PIManalyzer:FULL?	4-18
:CALibration:STATe?	5-11
:CONFigure:MEASure:1PHase	5-13
:CONFigure:MEASure:ACTiveChan 0 1	
:CONFigure:MEASure:ACTiveChan?	5-12
:CONFigure:MEASure:DUALdisplay DUAL SINGLE	
:CONFigure:MEASure:DUALdisplay?	5-12
:CONFigure:MEASure:RLDTf	5-12
:CONFigure:MEASure:RLFReq	5-13
:CONFigure:MEASure:SMCHart	5-13
:CONFigure:MEASure:SWRDtf	5-13
:CONFigure:MEASure?	5-12
:DISPlay:WINDow:TRACe:Y[:SCALE]:AUToscale	5-14
:DISPlay:WINDow:TRACe:Y[:SCALE]:BOTTOm <value>	5-14
:DISPlay:WINDow:Trace:Y[:SCALE]:PDIVision	
:DISPlay:WINDow:Trace:Y[:SCALE]:PDIVision?	4-19
:DISPlay:WINDow:Trace:Y[:SCALE]:RLEVel	
:DISPlay:WINDow:Trace:Y[:SCALE]:RLEVel?	4-19
:DISPlay:WINDow:TRACe:Y[:SCALE]:SMCHart 0 10 20 30 -3	
:DISPlay:WINDow:TRACe:Y[:SCALE]:SMCHart?	5-15
:DISPlay:WINDow:TRACe:Y[:SCALE]:TOP <value>	5-14
:FETCh:GPS?	3-2
:FORMat[:READings][:DATA] ASCii INTeger,32 REAL,32	
:FORMat[:READings][:DATA]?	5-16
:INITiate:CONTInuous OFF ON 0 1	
:INITiate:CONTInuous?	5-19
:INITiate:HOLD OFF ON 0 1	
:INITiate:HOLD?	5-19
:INITiate:PIManalyzer:MEASure OFF ON 0 1	4-20
:INITiate:PIManalyzer:PVT:ALLPower:CAL	4-20
:INITiate:PIManalyzer:RESidual:CAL	4-20
:INITiate[:IMMEDIATE]	5-20
:INSTrument:CATalog:FULL?	3-3
:INSTrument:NSElect <integer>	
:INSTrument:NSElect?	3-3
:INSTrument[:SElect] <string>	
:INSTrument[:SElect]?	3-4
:MMEMory:CABLElist:RESet	4-21
:MMEMory:DATA? <file name>	3-5
:MMEMory:DELeTe <file name>	5-21
:MMEMory:LOAD:STATe <integer>,<file name>	4-22
:MMEMory:LOAD:STATe <integer>,<file name>	5-21
:MMEMory:LOAD:TRACe <integer>,<file name>	4-21
:MMEMory:LOAD:TRACe <integer>,<file name>	5-22

:MMEMory:MSIS INTernal USB	
:MMEMory:MSIS?	3-5
:MMEMory:MSIS:COPI	3-6
:MMEMory:MSIS:DESTInation INTernal USB	
:MMEMory:MSIS:DESTInation?	3-7
:MMEMory:STORe:JPEg <file name>	3-7
:MMEMory:STORe:STATe <integer>,<file name>	4-23
:MMEMory:STORe:STATe <integer>,<file name>	5-22
:MMEMory:STORe:TRACe <integer>,<file name>	4-22
:MMEMory:STORe:TRACe <integer>,<file name>	5-23
:SYSTem:OPTions?	3-10
:SYSTem:PRESet	3-10
:TRACe:PREAmble? [1]	5-24
:TRACe[:DATA]? [1]	5-24
:TRACe[:DATA]? <X>	4-38
[[:SENSe]:AVERAge:CLEAr	5-25
[[:SENSe]:AVERAge:COUNT <integer>	
[[:SENSe]:AVERAge:COUNT?	5-25
[[:SENSe]:AVERAge[:STATe] OFF ON 0 1	
[[:SENSe]:AVERAge[:STATe]?	5-25
[[:SENSe]:CORRection:COLLect:ABORT	5-26
[[:SENSe]:CORRection:COLLect:INITialize	5-26
[[:SENSe]:CORRection:COLLect:LOAD	5-26
[[:SENSe]:CORRection:COLLect:OPEN	5-27
[[:SENSe]:CORRection:COLLect:SHORT	5-27
[[:SENSe]:CORRection:COLLect:STATus? [INITialize OPEN SHORT LOAD] . . .	5-28
[[:SENSe]:CORRection:TYPE STANDARD FLEX	
[[:SENSe]:CORRection:TYPE?	5-28
[[:SENSe]:DTPMeas:AVERAge:TYPE	
[[:SENSe]:DTPMeas:AVERAge:TYPE?	4-24
[[:SENSe]:DTPMeas:DISPlay:BOTTOm	
[[:SENSe]:DTPMeas:DISPlay:BOTTOm?	4-24
[[:SENSe]:DTPMeas:DISPlay:TOP	
[[:SENSe]:DTPMeas:DISPlay:TOP?	4-25
[[:SENSe]:DTPMeas:ENREsolution ON OFF	
[[:SENSe]:DTPMeas:ENREsolution?	4-25
[[:SENSe]:FREQuency:CABLe <index>	5-28
[[:SENSe]:FREQuency:LINK UPLINK DOWNLINK UPANDDWNLINK	
[[:SENSe]:FREQuency:LINK?	5-29
[[:SENSe]:FREQuency:SIGStandard:NAME <string>	
[[:SENSe]:FREQuency:SIGStandard:NAME?	5-29
[[:SENSe]:FREQuency:STARt <freq>	
[[:SENSe]:FREQuency:STARt?	5-30
[[:SENSe]:FREQuency:STOP <freq>	
[[:SENSe]:FREQuency:STOP?	5-30
[[:SENSe]:GPS:CURRent?	3-9
[[:SENSe]:GPS:RESet	3-8
[[:SENSe]:GPS:VOLTagE 0 1	
[[:SENSe]:GPS:VOLTagE?	3-9
[[:SENSe]:GPS	

Appendix D — List of Commands, Alphabetical

[.SENSe]:GPS?	3-8
[.SENSe]:PIManalyzer:AUTorange OFF ON 0 1	
[.SENSe]:PIManalyzer:AUTorange?	4-26
[.SENSe]:PIManalyzer:AVERaging FAST LOWNoise	
[.SENSe]:PIManalyzer:AVERaging?	4-26
[.SENSe]:PIManalyzer:DTPMeas:LRDTf:START?	4-27
[.SENSe]:PIManalyzer:DTPMeas:LRDTf:STOP?	4-27
[.SENSe]:PIManalyzer:DTPMeas:LRDTf[:STATE]	
[.SENSe]:PIManalyzer:DTPMeas:LRDTf[:STATE]?	4-27
[.SENSe]:PIManalyzer:FREQuency:F1 2	
[.SENSe]:PIManalyzer:FREQuency:F1 2?	4-28
[.SENSe]:PIManalyzer:FREQuency:STEP	
[.SENSe]:PIManalyzer:FREQuency:STEP?	4-28
[.SENSe]:PIManalyzer:HIReflection:BYPass	
[.SENSe]:PIManalyzer:HIReflection:BYPass?	4-29
[.SENSe]:PIManalyzer:IMD:ORDer	
[.SENSe]:PIManalyzer:IMD:ORDer?	4-29
[.SENSe]:PIManalyzer:IMFReq:BAND LOW HIGH	
[.SENSe]:PIManalyzer:IMFReq:BAND?	4-30
[.SENSe]:PIManalyzer:MEASure:STATus?	4-30
[.SENSe]:PIManalyzer:MEASure:VALue?	4-31
[.SENSe]:PIManalyzer:MODE PIM PIMSwp DTP SPECTRUM_VIEW	
[.SENSe]:PIManalyzer:MODE?	4-31
[.SENSe]:PIManalyzer:OUTPut:POWer	
[.SENSe]:PIManalyzer:OUTPut:POWer?	4-32
[.SENSe]:PIManalyzer:RF:OUTput ON OFF	
[.SENSe]:PIManalyzer:RF:OUTput?	4-32
[.SENSe]:PIManalyzer:SPECTrum:CURRent:FREQuency?	4-33
[.SENSe]:PIManalyzer:SPECTrum:CURRent:MEASure:VALue?	4-33
[.SENSe]:PIManalyzer:SPECTrum:MAX:FREQuency?	4-34
[.SENSe]:PIManalyzer:SPECTrum:MAX:MEASure:VALue?	4-33
[.SENSe]:PIManalyzer:SWEEp:FREQuency:F1:START	
[.SENSe]:PIManalyzer:SWEEp:FREQuency:F1:START?	4-35
[.SENSe]:PIManalyzer:SWEEp:FREQuency:F1:STOP	
[.SENSe]:PIManalyzer:SWEEp:FREQuency:F1:STOP?	4-35
[.SENSe]:PIManalyzer:SWEEp:FREQuency:F1 2?	4-34
[.SENSe]:PIManalyzer:SWEEp:FREQuency:F2:START	
[.SENSe]:PIManalyzer:SWEEp:FREQuency:F2:START?	4-36
[.SENSe]:PIManalyzer:SWEEp:FREQuency:F2:STOP	
[.SENSe]:PIManalyzer:SWEEp:FREQuency:F2:STOP?	4-36
[.SENSe]:PIManalyzer:SWEEp:IMD:ORDer	
[.SENSe]:PIManalyzer:SWEEp:IMD:ORDer?	4-37
[.SENSe]:PIManalyzer:TEST:DURation	
[.SENSe]:PIManalyzer:TEST:DURation?	4-37
[.SENSe]:SWEEp:RESolution 137 275 551 1102 2204	
[.SENSe]:SWEEp:RESolution?	5-31
[.SENSe]:SWEEp:RFIMmunity 0 1	
[.SENSe]:SWEEp:RFIMmunity?	5-31

Anritsu



Anritsu utilizes recycled paper and environmentally conscious inks and toner.

Anritsu Company
490 Jarvis Drive
Morgan Hill, CA 95037-2809
USA
<http://www.anritsu.com>